

Secures everything in transit™

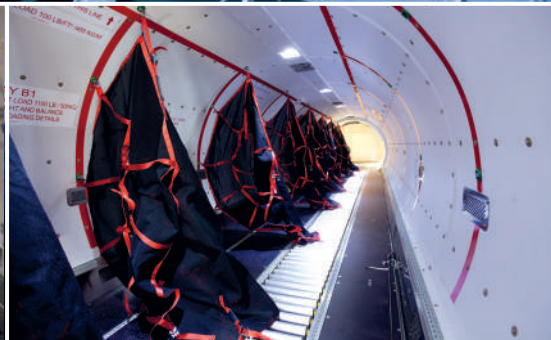
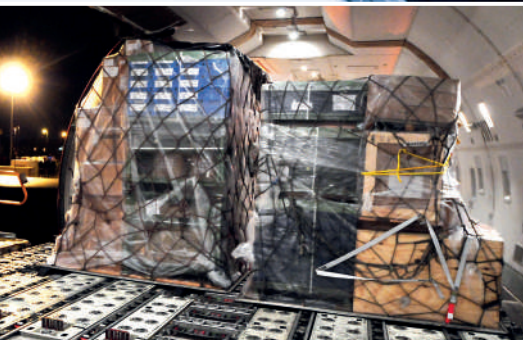

Restraint solutions
for the aerospace industry

 **GPI forankra**
CARGO NETS AND RESTRAINT SOLUTIONS

SOMMAIRE

Cargo

Cargo pallet net description	6
Cargo pallet net advantages	7
PMC/PAG light weight cargo net	8-9
PLA light weight cargo net	8-9
PKC light weight cargo net	8-9
PGA/PGF light weight cargo net	8-9
Tie down strap ETSO C-172 description	10-11
Thermal cover & Fire containment Cover	12
Spare parts - vehicule strap / cargo stopper / fitting / security seal / Secu stick	13
Microlight harness solution	14

OEM Solutions

Solutions for aircraft manufacturers, tier 1 suppliers and mro companies	16
Airframe 9g barrier nets	17
Luggage nets.....	18
Custom straps and floor nets.....	19
Tailor made securing solutions	20

Spare parts

Webbings.....	22
Seat track	23
Overcenter buckles and cam buckles	24
Ratchet buckles	25
Slides buckles	26
Spare parts	27-28

Military

Cargo securing solution for NH-90 helicopters	30
Cargo securing solution for SUPER PUMA AS332 helicopters	31
Certified tie down straps ETSO C172	32
Tie down strap for military air transport	33
Tie down strap to secure helicopters on aircrafts carrier	33
Top & side cargo nets for HCU-6 pallet	34
One piece EASA certified cargo net for HCU-6 pallet	35
One piece EASA certified cargo net for 2 coupled HCU-6 pallet	36
Underslung lifting net	37
Easa certified cargo net for PMC/PAG pallet	38

Other products from the Forankra group

Road lashing	40
One way securing	40
Dock equipment	41
Lifting	41

FORANKRA GROUP

Forankra offers products and customized solutions in cargo securing, lifting and cargo optimization through the whole logistic chain – from straps and lashings to technically advanced cargo securing systems for all kinds of road, air and sea transports.

With our knowledge and expertise, we help our customers **to secure everything in transit.**

GPI FORANKRA

For nearly 40 years, GPI Forankra has been designing, developing and manufacturing all types of cargo restraint systems for the aerospace industry. Our range of products includes ETSO/TSO and STC approved products as well as tailor made solutions:

- >> **Air cargo products:** TSO cargo nets, Tie down Straps, fittings, lashing ropes, thermal covers, spider nets and webbings...
- >> **Aerospace restraint systems:** 9G barrier nets, luggage nets, straps assembly, stow away pockets, fire proof cargo bags...
- >> **Military products:** 9G cargo nets, tie down straps, lifting nets, lifting slings, special fittings...

Our customers:

>> **Air cargo companies and handlers**

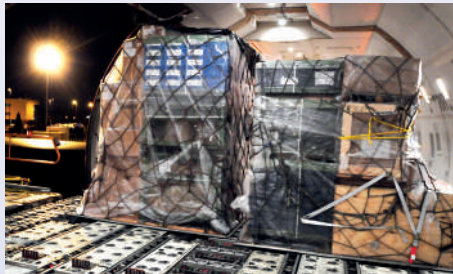

>> **OEM, MRO and Tier 1 suppliers**

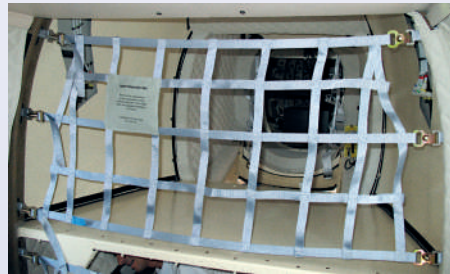

>> **Air forces, navy, military**



MISSION & VISION

Our mission is to make **handling and transport by air efficient and safe.**

Our vision:

>> **SAFETY**

All our products are designed according to the highest international standards to ensure the security of the final users.

>> **QUALITY**

Our workers have an average of over 20 years of experience and only use best in class components and material.

>> **FLEXIBILITY**

Our workshop is designed to be flexible so that we can propose short lead times and even AOG conditions when necessary.

>> **INNOVATION**

Our clients each have specific requirements so innovation is key for our R&D department.

PRODUCTION IN FRANCE

All our products are manufactured in our own facility in Angers France (**COUNTRY OF ORIGIN: FRANCE**). This gives us total control over the quality of our products and allows us to provide very competitive lead times and prices all over the EMEA area and beyond



CERTIFICATION

GPI Forankra is fully approved **PART 21 subpart G and certified ISO 9001.**

PART 21 sub G: Production Organisation Approval (POA) is managed by EASA. It approves manufacturing process and quality control management of GPI Forankra production.

ISO 9001: This certification is a quality management standard. It defines a set of quality management requirements.

EASA Form 1 certificate can be delivered with all our standard products.

Cargo

Cargo pallet net description	6
Cargo pallet net advantages	7
PMC/PAG light weight cargo net	8-9
PLA light weight cargo net	8-9
PKC light weight cargo net	8-9
PGA/PGF light weight cargo net	8-9
Tie down strap ETSO C-172 description	10-11
Thermal cover & Fire containment Cover	12
Spare parts - vehicle strap / cargo stopper / fitting / security seal / Multi-stick	13
Microlight harness solution	14



TSO/ETSO C90C CERTIFIED CARGO PALLET NETS

A FULL RANGE OF CERTIFIED PRODUCTS

Over the years, the regulation concerning cargo products has evolved and GPI Forankra has always been proactive to certify all its products long before the norms were mandatory.

>> GPI is a certified Part 21 G organization since 1999 and:

- All GPI's cargo nets have been designed in compliance with **NAS 3610**.
- All GPI's cargo nets have received a **TSO/ETSO C90c** certification.
- All GPI's tie-down straps were designed in compliance with **ISO 16 049-1**.
- All GPI's tie-down straps have received a **TSO/ETSO C172** certification.



Component and maintenance manuals (CMM) are available to our customers and our products are delivered with an **EASA Form 1 certificate**.



HIGH QUALITY, LOW COST, FLEXIBILITY

GPI is probably the last specialized air cargo restraint manufacturer with full production capacity in Europe. All our products are assembled and inspected in France which gives us total control over quality.

Our optimized production organization allows us to keep our prices very competitive from small and urgent orders to long term larger contracts.

Because we produce on site, we are able to provide short lead times when necessary, even for personalized orders (specific markings, placards, logo...).



FOCUS ON WEIGHT REDUCTION

GOOD FOR THE ENVIRONMENT AND YOUR BUDGET

“The aviation industry pledged to reduce carbon emissions by 50% of 2005 level by 2050 despite an important projected growth.”
To achieve this, reducing weight in aircrafts is key: today to reduce fuel consumption, tomorrow to allow for electric planes to be viable perhaps.

In order to contribute to this effort, GPI is always pushing to reduce its products’ weight.

Most polyester nets on the market are 50% heavier than our extra light nets, this represents several hundred kilograms of unnecessary cargo that increase fuel consumption significantly.

In a world where kerosene cost will keep rising, saving 3 to 6kg for each net will not only reduce your company’s carbon footprint, but will actually **make you save more money than the actual cost of the net itself over its lifetime!**

WHY USE LIGHT WEIGHT GPI NETS ?

According to the FAA, 1kg of extra cargo weight = 100kg of extra fuel consumption each year !

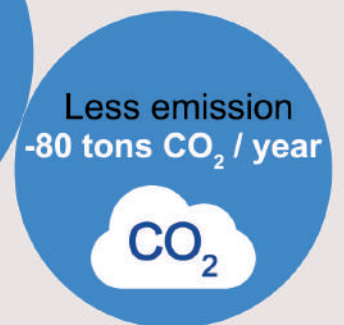
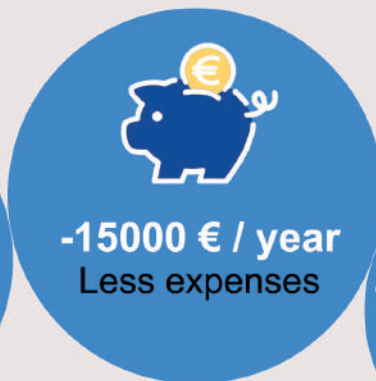
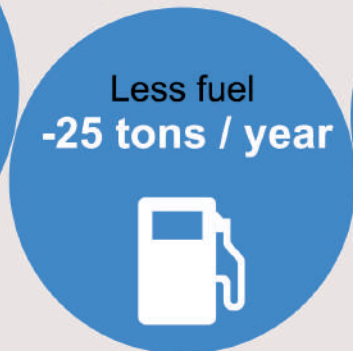

GPI nets total cost of ownership is actually negative over their lifetime if you use them to replace standard heavier nets !

The above figures are based on FAA research, comparing GPI light weight PMC nets with standard 18kg cargo nets, with an average flying time of 3000 hours per year.

LIGHT WEIGHT NET EXTRA RANGE

Net to secure your cargo on air cargo pallet.

All components and construction of the pallet net meet the requirements of **IATA standard specification 50/1 and 50/2.**

Conform to NAS 3610 and approved ETSO/TSO C90c.

EASA form 1 certificate / Component and Maintenance Manual (CMM)

Made of polyester slotted webbing 13mm, with mesh type 250 x 250 mm knotless.

LASHING LINE	4 lashing lines
TENSIONNING	24 adjusting hooks
FITTING	18 double studs fittings (5000 lbs) ISO 9788, all drilled for permanent fixture with 3 mm hole
MARKING	2 central placards size 300 x 150 mm with net size, maximum gross weight and pallet type

13 mm Polyester webbing



Tensioning hook



Double stud



Central placard

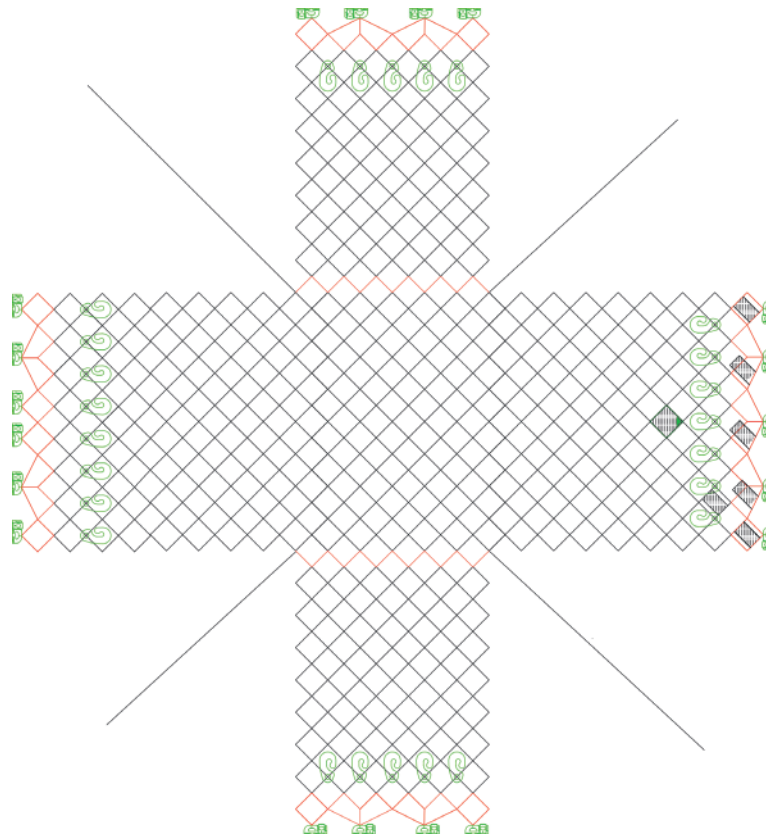

OPTIONS

Company logo on central placard

Light weight ergonomic hook



ODLN placard



LIGHT WEIGHT NET EXTRA RANGE



PMC/PAG CARGO NET

P/N	2M2N-B2-064-30	2M2N-B2-096-30	2M2N-B2-118-30
DIMENSIONS	88/96 x 125 x 64"	88/96 x 125 x 96"	88/96 x 125 x 118"
HEIGHT	64"	96"	118"
WEIGHT	9,4 kg	10,3 kg	11,9 kg

PLA CARGO NET

P/N	2L3N-064-B1-21	2L3N-064-B1-22
DIMENSIONS	60,4 x 125 x 64"	60,4 x 125 x 80-90"
HEIGHT	64"	80"
WEIGHT	8,2 kg	9 kg

PKC CARGO NET

P/N	2K3N-064-B1-01	2K3N-064-B1-02
DIMENSIONS	60,4 x 61,5 x 64"	60,4 x 61,5 x 80"
HEIGHT	64"	80"
WEIGHT	6,3 kg	7 kg

PGA/PGF CARGO NET

P/N	2G1N-096-R2-12	2G1N-096-R2-10
DIMENSIONS	96 x 238,5 x 96"	96 x 238,5 x 118"
HEIGHT	96"	118"
WEIGHT	24 kg	28 kg

Other dimensions available on demand.

All our references pages 42-43

TIE DOWN STRAP ETSO C-172

SLT range - 907 KG / 2000 LBS

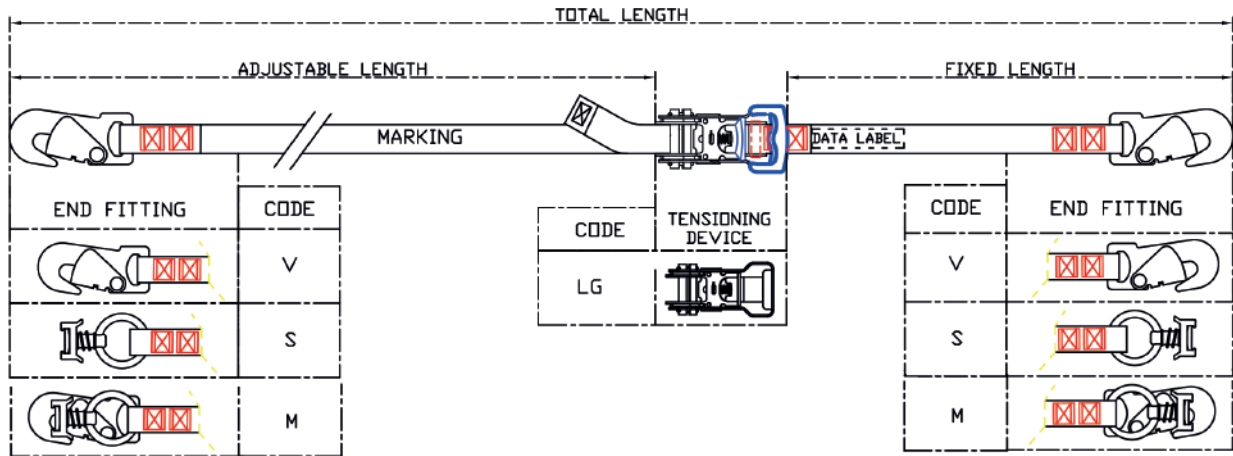

ST range - 2268 KG / 5000 LBS

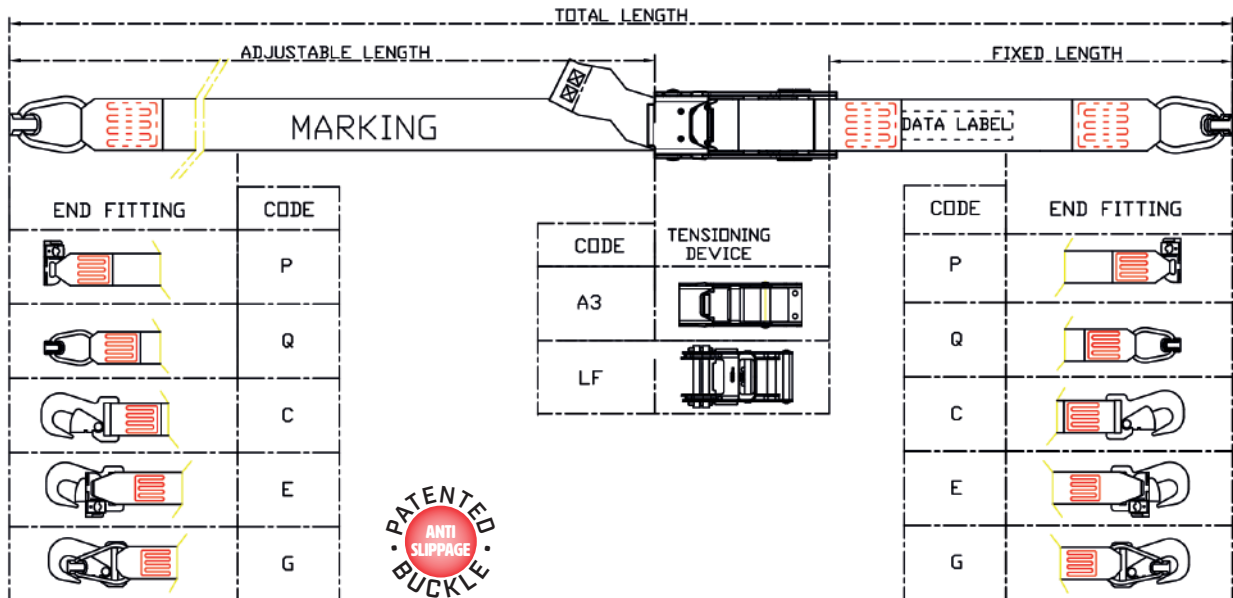

SHT range - 4536 KG / 10 000 LBS

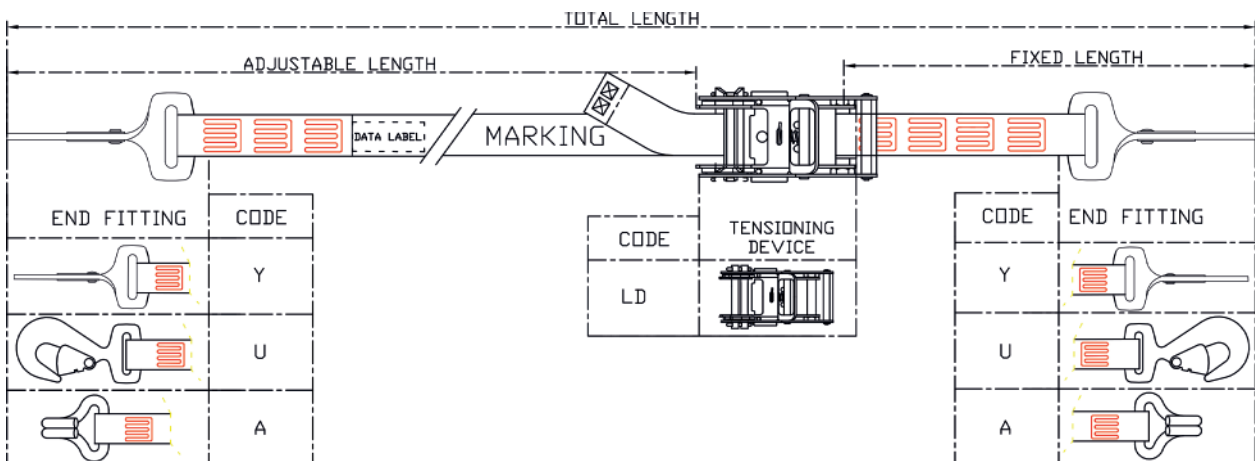

TIE DOWN STRAP ETSO C-172



TECHNICAL SPECIFICATIONS

RANGE	SLT	ST	SHT
DESCRIPTION	High quality tie down strap to secure your cargo on air cargo pallet and in aircraft structure		
CERTIFICATION	EASA Certified ETSO C172 - Delivered with EASA FORM ONE certificate		
ULTIMATE LOAD	907 kg / 2000 lbs	2268 kg / 5000 lbs	4536 kg / 10 000 lbs
TOTAL LENGTH	Standard: 6, 9, 12 meters - Other length on request		
FIXED LENGTH	Standard: 1 meter - Other length on request		
WEBBING	Polyester - 25 mm width	Polyester - 45 mm width	Polyester - 50 mm width
COLOR	Standard: white, blue, red - Other color on request		
MARKING	On request		
END FITTING	V = Flat snap hook S = Single stud M = Flat snap hook + Single stud	P = Double stud Q = Double stud with ring C = Flat snap hook E = Flat snap hook + Double stud G = Flat snap hook + Double stud with ring	Y = Twisted snap hook U = Flat snap hook A = Double J hook with retainer
TENSIONING DEVICE	LG = Ratchet buckle	A3 = Over center buckle LF = Ratchet buckle	LD = Ratchet buckle
LIFE LIMIT	5 years		

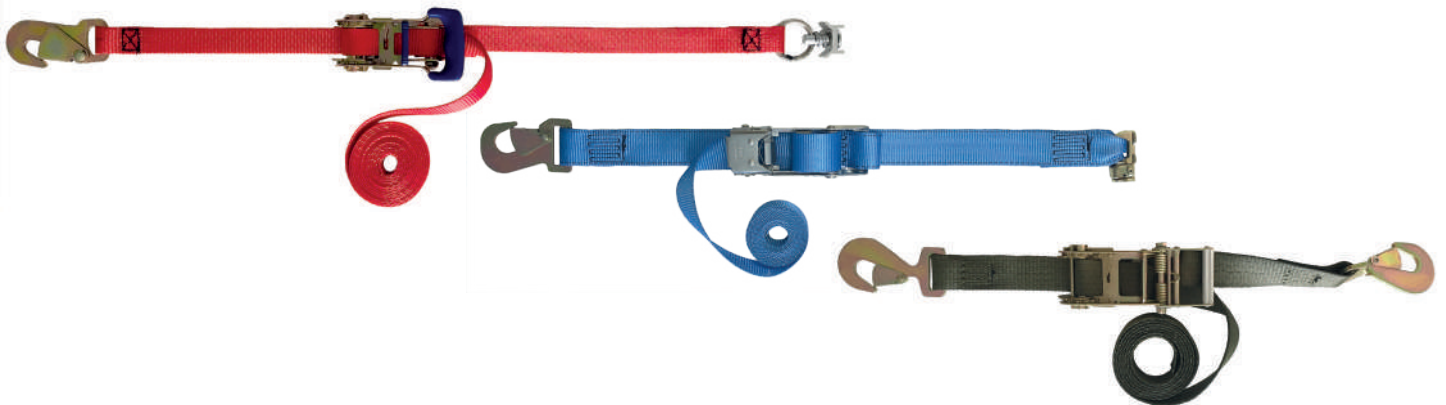

All our references pages 42-43

THERMAL COVER FOR SEMI FRESH & CEIV PHARMA CARGO

P/N: GP TCXXXXXX

Secure transport of semi fresh & pharmaceutical product
Compliance: FAR 25 requirements
Easy to install / operate

DIMENSIONS: any pallet size - any height
Water proof fabric
Closing by velcro
5 sides or 6 sides covers
For temperatures from -30°C to 60°C

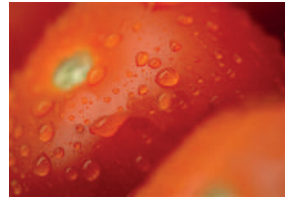

FIRE CONTAINMENT COVER FOR FLAMMABLE CARGO

NSN: 4210-14-563-7900

P/N: FCB-096-50

Secure transport of flammable product
Compliance: FAR/CS 25 cargo class F
Easy to install / operate

DIMENSIONS: any pallet size - any height
TIE DOWN FITTINGS: Single studs or hooks
Fire extinguisher holes included

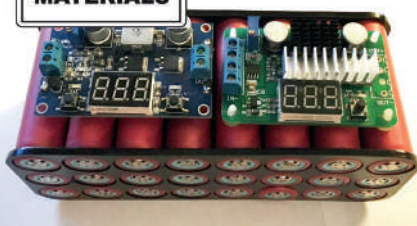
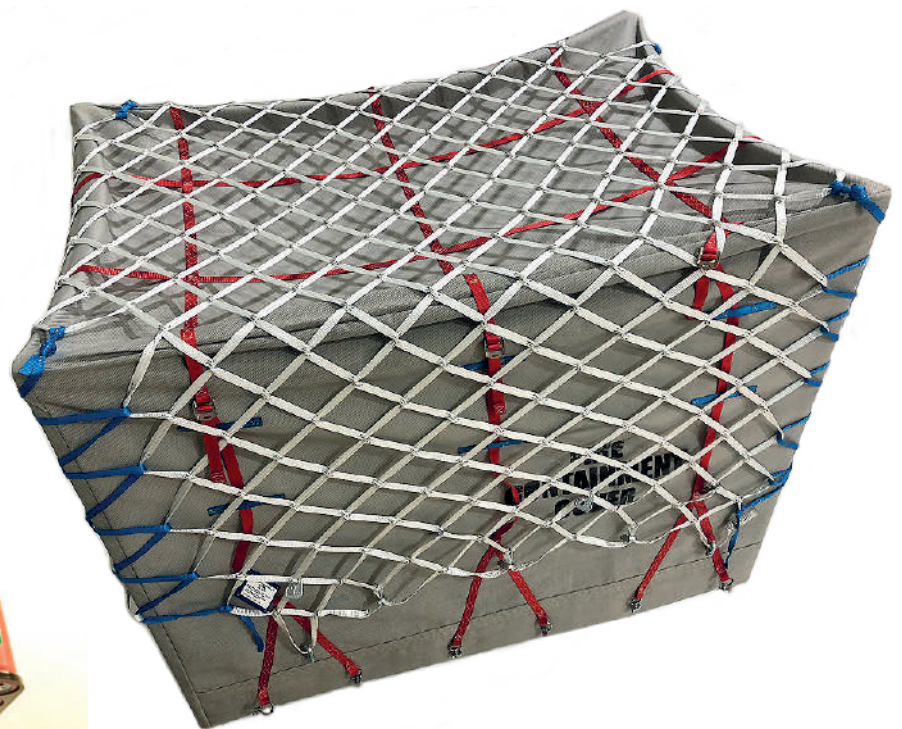

SPARE PARTS

VEHICULE STRAP - CONFORM FAR25.853

P/N	SR2PL5-400
ULTIMATE LOAD	2268 kg / 5000 lbs
DIMENSIONS	Ajustable to every wheel dimensions



CARGO STOPPER - CONFORM SAE AS6022

P/N	STP 120 / STP 140
ULTIMATE LOAD	2268 kg / 5000 lbs
DIAMETER	1200 / 1400 mm

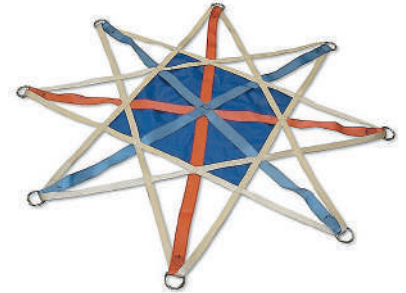

FITTING - CONFORM ISO

P/N	FS 700 - Single stud with ring	FS 2000 AP - Double stud with ring
ULTIMATE LOAD	2200 kg / 4850 lbs (vertical)	3300 kg / 7275 lbs (vertical)
CONFORM	ISO 7166	ISO 9788



SECURITY SEAL

P/N	PLSCC15-250	PLSCC35-250	PLSCC50-250
DIAMETER	1,5 mm	3,5 mm	5 mm
LENGTH	250 mm		



MULTI-STICK

Adjustable pike pole to handle cargo nets

P/N	GP MSSS1030
LENGTH	1 m to 2,70 m
WEIGHT	855 g



All our references pages 42-43

ULTRA LIGHT SAFETY BELT SYSTEMS



From aerospace to microlight.

HIGHT QUALITY & SECURITY

GPI Forankra restraint solutions have been developed to fulfill the most demanding safety requirements. Manufactured in France by experienced workers, our products offer the highest quality.

ULTRA-LIGHT WEIGHT

For many years, GPI Forankra has focused its R&D efforts on light weight textile restraint solutions for aerospace industry.

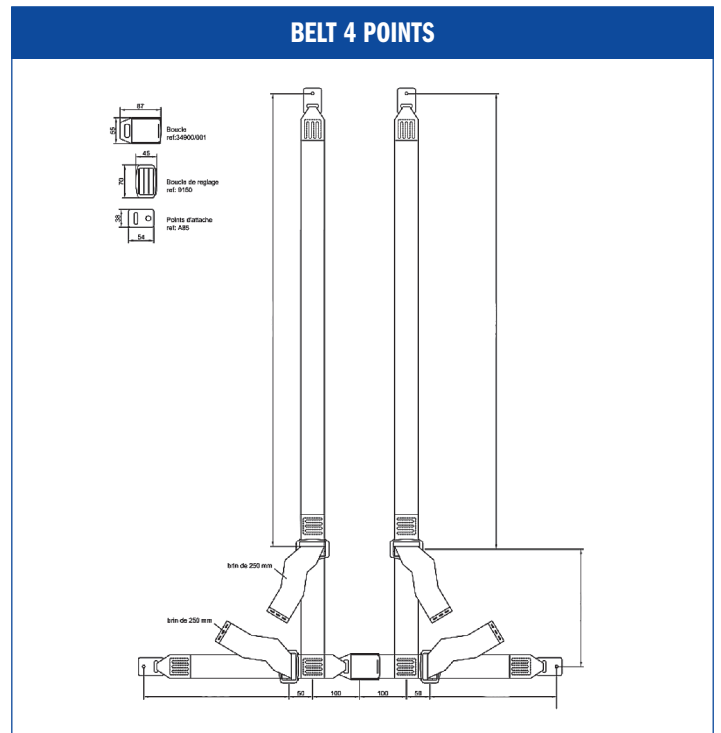
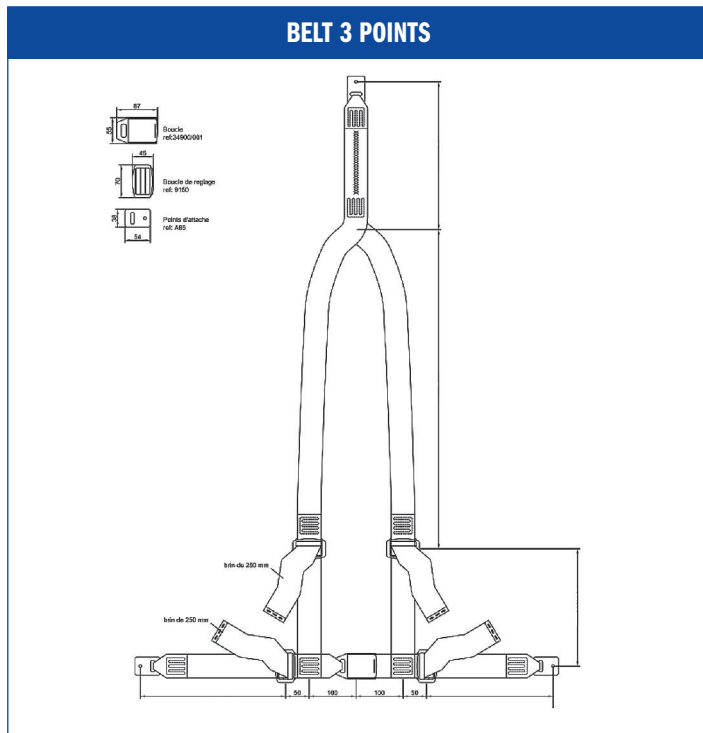

STRAP COLOR	Black, red, grey
BUCKLE	Plane or plastic type
HARDWARE	Plate or ring
MARKING	We can make any marking: compagny name, logo... black and white, color...



Plane type



Plate



Ring

OEM Solutions

Solutions for aircraft manufacturers, tier 1 suppliers and mro companies	16
Airframe 9g barrier nets	17
Luggage nets.....	18
Custom straps and floor nets.....	19
Tailor made securing solutions	20



SOLUTIONS FOR AIRCRAFT MANUFACTURERS, TIER 1 SUPPLIERS AND MRO COMPANIES

SECURING ANYTHING THAT FLIES

For over 40 years, GPI has been collaborating with the biggest names in the industry to design and develop tailor made solutions for all types of aircrafts. From stow away pockets in helicopters to 9G barrier nets in cargo planes, we can help you secure anything.



SUPPORTING YOU ALL THE WAY FROM CONCEPT TO PRODUCT CERTIFICATION

Our international R&D team and our prototyping experts collaborate to propose innovative designs that meet all safety requirements, while minimizing weight and optimizing operations.

We support our clients through the whole certification process, providing all necessary tests reports, material certifications, calculations and justifications to get the product certified by your local regulator.

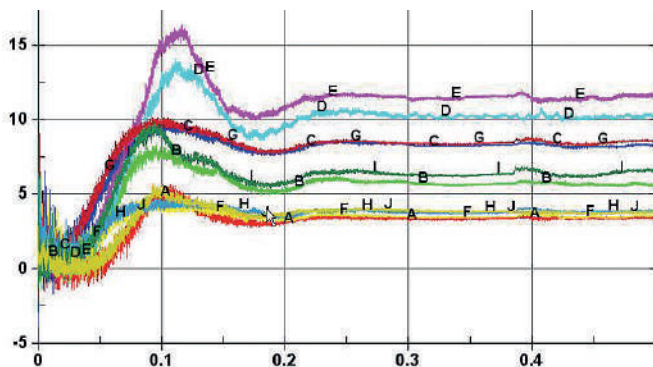
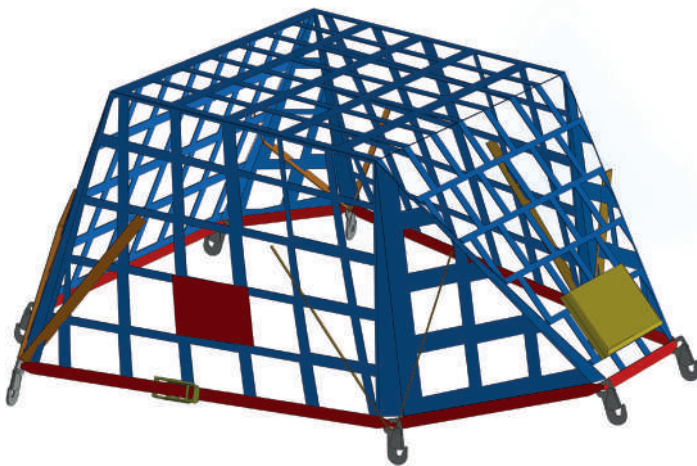

AIRFRAME 9G BARRIER NETS

GPI has developed 9G barrier nets with clients specialized in cargo conversions. Our range includes nets for ATR and Saab planes and we can propose solutions for any other aircraft.

ATR 9G BARRIER NET

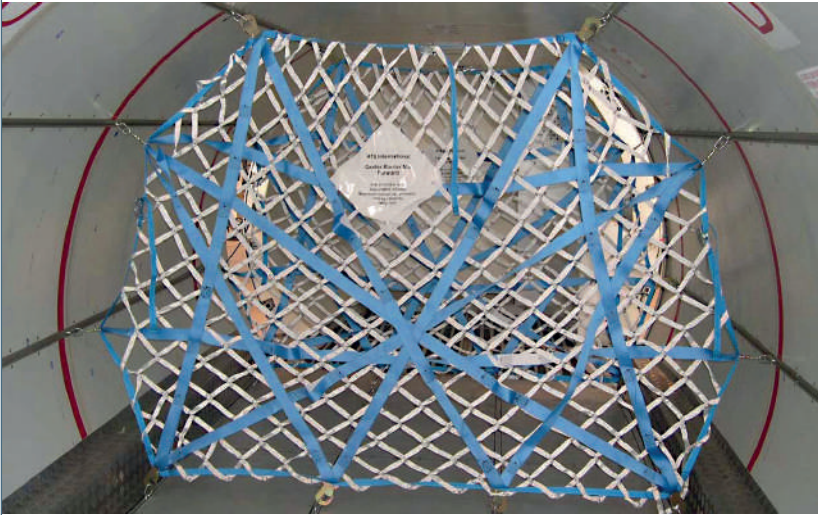

Set of 9G barrier nets for ATR 42 and ATR 72, allowing for the conversion of passenger planes to cargo aircraft. Contains front, center, aft and door nets.

P/N	GPI ref
0110-09-0A-6100EPA	GP AT3000-01
0110-09-0A-6101EPA	GP AT3010-01
9000-01-A-6017-F01EPA	GP AT3017-01
0110-09-0A-6102EPA	GP AT3012
9000-01-A-6018-F01EPA	GP AT3018

SAAB 9G BARRIER NET

Set of 9G barrier for aircraft such as the Saab 340, allowing for the conversion of passenger planes to cargo aircraft.

Contains forward, door and main cabin nets.

P/N	GPI ref
25-63-10300	GP TA151-6
25-63-10301-2	GP TA156-3
25-63-10299-1	GP TA153-1

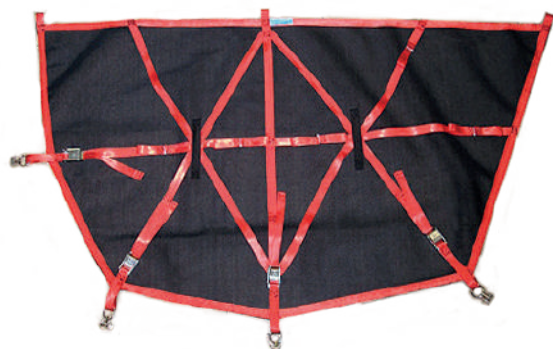

LUGGAGE NETS

From business jets to leisure aircraft, from helicopters to the biggest cargo planes, we have developed all sorts of nets to secure luggage.

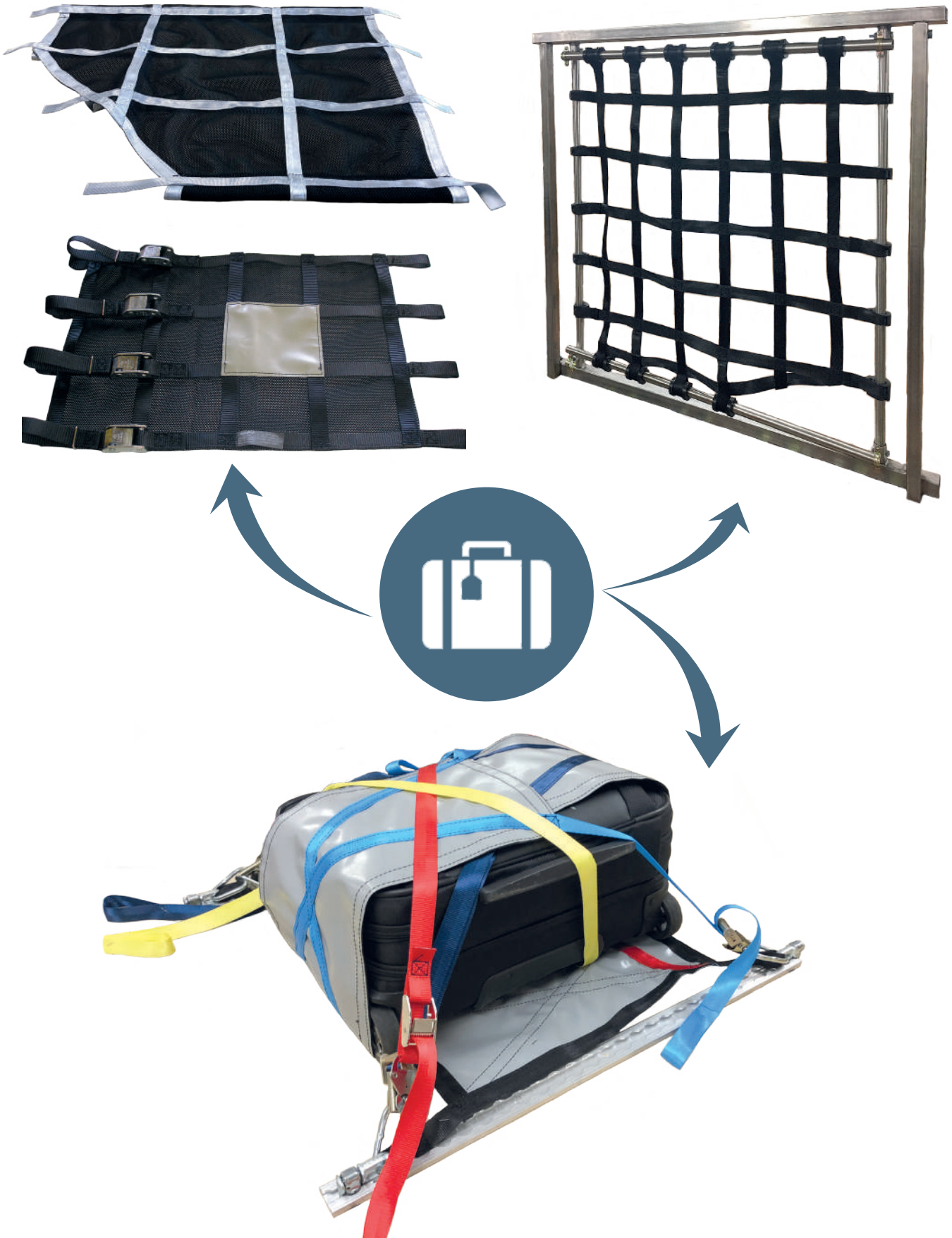

CUSTOM STRAPS AND FLOOR NETS

Our long experience and wide range of available parts allow us to propose all sorts of custom straps and floor nets to fit your exact need.



TAILOR MADE SECURING SOLUTIONS

- Strap assembly solution to secure a 1 ton load in an helicopter for stress test flights

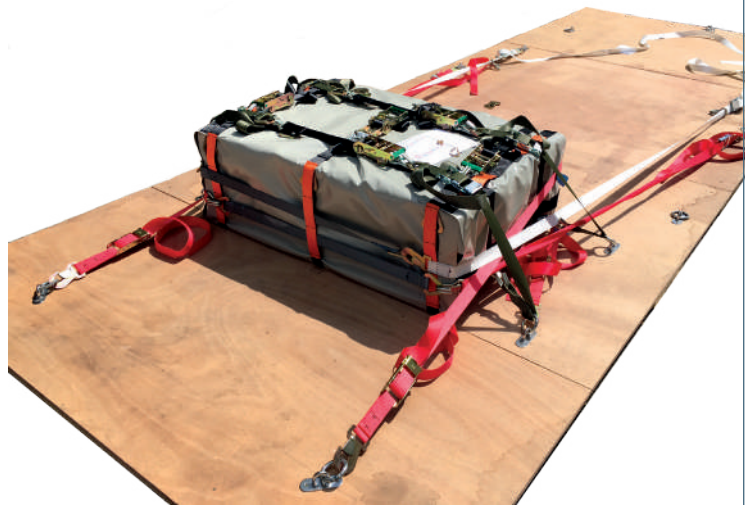

- Special sleeve net, tailor made to secure scientific equipment in a test plane

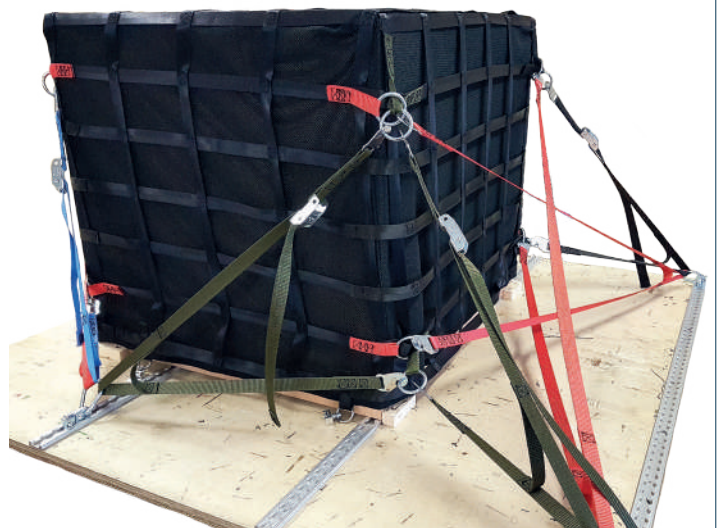

Spare parts

Webbings.....	22
Seat track	23
Overcenter buckles and cam buckles	24
Ratchet buckles	25
Slides buckles	26
Spare parts	27-28



GPI holds in stock a wide range of polyester webbings in different widths, colors and breaking strengths.

All of them comply with FAR 25 appendix F, and are fully approved for use in an airplane. In addition to our standard range, we can supply almost any other dimensions, breaking strengths or colors.

SLOTTED WEBBINGS

P/N	723/13 B	723/13 R	723/18
COLORS	White		
WIDTH	13 mm	15 mm	18 mm
MATERIAL	PES		
ULTIMATE LOAD	1250 daN	1500 daN	2000 daN



FLAT WEBBINGS - 20/45 mm

P/N	1163/20	84 044/25-N0	98 323/25	20 319/25	5264A-044
CONFORMITY WITH	ASNA 3573-5919	ASNA 3573-5926	ASNA 3573-5925	-	-
COLORS	Black	Black	Grey	White, blue, red, grey, green	
WIDTH	20 mm	25 mm	25 mm	25 mm	45 mm
MATERIAL	PES				
ULTIMATE LOAD	700 daN	1200 daN	1200 daN	2000 daN	3100 daN



FLAT WEBBINGS - 48/75 mm

P/N	84 015/50-N0	85 017/50	94 187/50	93 168/50	6592/60	6551/75
COLORS	Black	Red, blue	White, blue, red, grey, green		Blue, orange, yellow	
WIDTH	48 mm	48 mm	50 mm	50 mm	60 mm	75 mm
MATERIAL	PES					
ULTIMATE LOAD	2500 daN	2500 daN	5000 daN	7500 daN	9000 daN	15 000 daN



TUBULAR WEBBINGS

P/N	724/15
COLORS	White, blue, red, yellow
WIDTH	15 mm
MATERIAL	PES
ULTIMATE LOAD	1800 daN

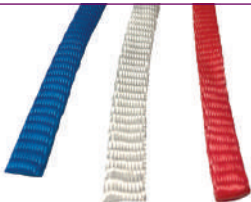

VELCRO

P/N	APL 800/xx M	APL 800/xx F
CONFORMITY WITH	ASNA 3546-1875	ASNA 3546-1825
COLORS	White, black, grey	
WIDTH	25 mm	



STRAP PROTECTION SHEATH

P/N	46 137-50	46 137-75
Flat webbing sleeve		
COLORS	PVC	
WIDTH	50 mm	75 mm



All our references pages 42-43

TARPOLIN

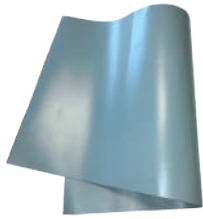

P/N	32 261 A	32 263 B
COLORS	Grey	Blue
MATERIAL	PES	

RASCHEL NETTING



P/N	FX 999
COLORS	Black
MATERIAL	Nylon

SEAT TRACK

ANCHOR PLATE

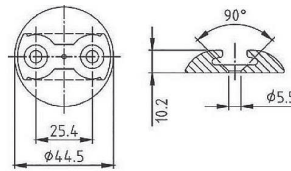

P/N	40000-11	ULTIMATE LOAD	1800 daN
MATERIAL	Aluminium	WEIGHT	20 g

DOUBLE ANCHOR PLATE

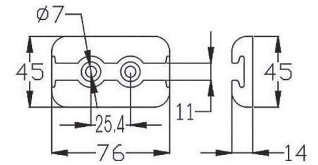

P/N	520 197-40	ULTIMATE LOAD	2500 daN
MATERIAL	Aluminium	WEIGHT	55 g

SEAT TRACKS

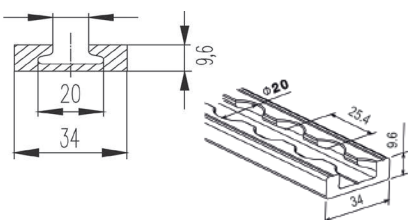

P/N	40 456-10	ULTIMATE LOAD	2000 daN
MATERIAL	Aluminium 7075	WEIGHT	0,57 kg/m

SEAT TRACKS

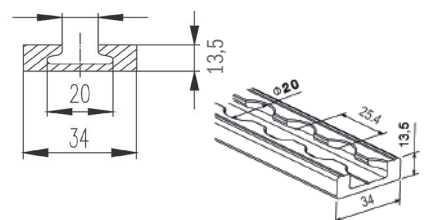

P/N	40 467-11	ULTIMATE LOAD	2700 daN
MATERIAL	Aluminium 7075	WEIGHT	0,9 kg/m

SEAT TRACKS

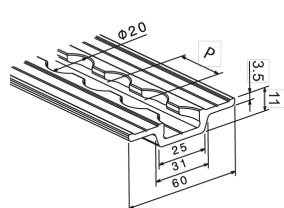

P/N	40 456-51	ULTIMATE LOAD	2000 daN
MATERIAL	Aluminium 6061	WEIGHT	0,92 kg/m

SEAT TRACKS

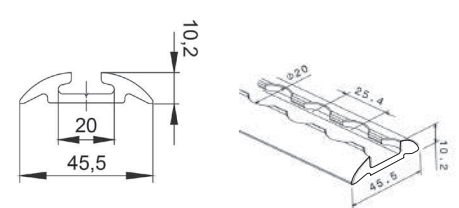

P/N	41 986-2000	ULTIMATE LOAD	1800 daN
MATERIAL	Aluminium 7075	WEIGHT	0,7 kg/m

All our references pages 42-43

OVERCENTER BUCKLES

P/N : 47 800-10

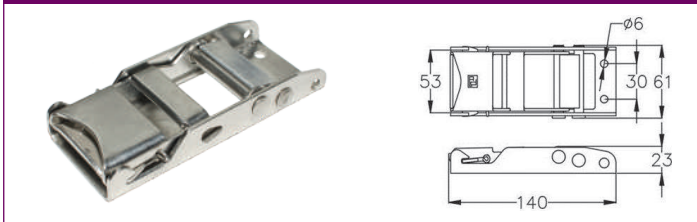

WEBBING	45 mm	ULTIMATE LOAD	2250 daN
MATERIAL	Steel - Zinc plated	WEIGHT	320 g

P/N : 48 857-20



WEBBING	45 mm	ULTIMATE LOAD	2250 daN
MATERIAL	Zinc plated	WEIGHT	435 g

P/N : 46 067-10



WEBBING	50 mm	ULTIMATE LOAD	800 daN
MATERIAL	Stainless steel	WEIGHT	240 g

P/N : 42 816-20

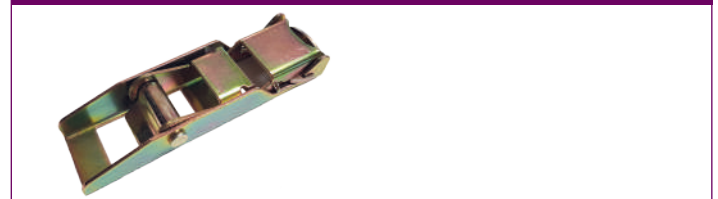

WEBBING	25 mm	ULTIMATE LOAD	2000 daN
MATERIAL	Steel - Zinc plated	WEIGHT	230 g

CAM BUCKLES

P/N : 41 030-17

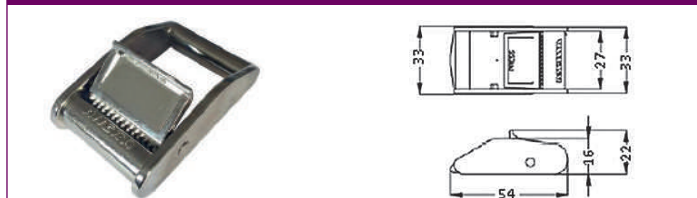

WEBBING	25 mm	ULTIMATE LOAD	250 daN
MATERIAL	Steel - Zinc plated	WEIGHT	60 g

P/N : 48 343-10

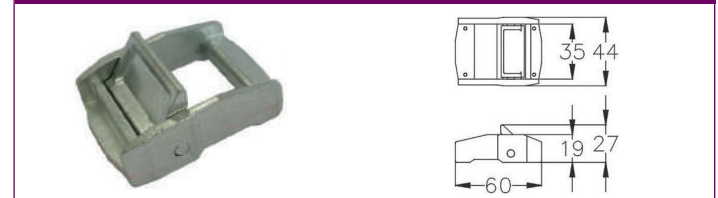

WEBBING	35 mm	ULTIMATE LOAD	700 daN
MATERIAL	Steel	WEIGHT	115 g

P/N : 42 195-10



WEBBING	25 mm	ULTIMATE LOAD	700 daN
MATERIAL	Steel - Zinc plated	WEIGHT	120 g

P/N : 40 880-19



WEBBING	45 mm	ULTIMATE LOAD	1100 daN
MATERIAL	Steel - Zinc plated	WEIGHT	252 g

RATCHET BUCKLES

P/N : 44 232-10

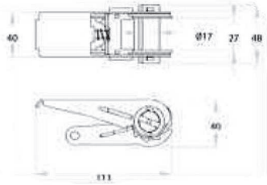
WEBBING	25 mm	ULTIMATE LOAD	750 daN
MATERIAL	Steel - Zinc-plated	WEIGHT	205 g

P/N : 44 232-10 SS





WEBBING	25 mm	ULTIMATE LOAD	750 daN
MATERIAL	Stainless steel	WEIGHT	230 g

P/N : 43 320-12



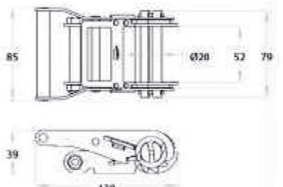

WEBBING	25 mm	ULTIMATE LOAD	2000 daN
MATERIAL	Steel - Zinc plated	WEIGHT	350 g

P/N : 46 405-10

WEBBING	50 mm	ULTIMATE LOAD	5000 daN
MATERIAL	Steel - Zinc plated	WEIGHT	525 g

P/N : 44 627-10

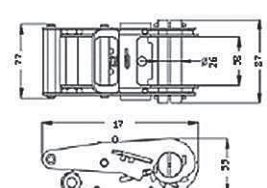
WEBBING	50 mm	ULTIMATE LOAD	5000 daN
MATERIAL	Steel - Zinc plated	WEIGHT	1005 g

P/N : 47 105-17

WEBBING	50 mm	ULTIMATE LOAD	5000 daN
MATERIAL	Stainless steel	WEIGHT	1065 g

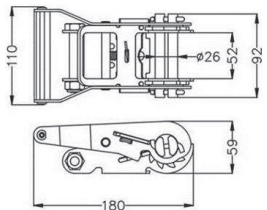
BUCKLE - P/N : 34900/001

		ULTIMATE LOAD	1300 daN
MATERIAL	Nickel - Zinc plated	WEIGHT	140 g

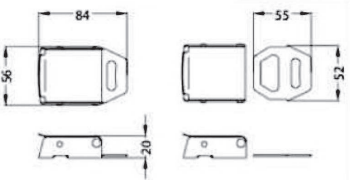
SNAP LATCH - P/N : 45 387-10

WEBBING	25 mm	ULTIMATE LOAD	680 daN
MATERIAL	Steel - Zinc plated	WEIGHT	77 g

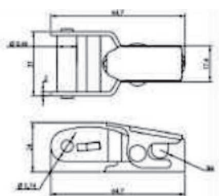
ONE TIME USE LASHING



Contact us for more details

SLIDES BUCKLES

P/N : 8023/25



A	B	C	ULTIMATE LOAD	800 daN
26	45	41	WEIGHT	45 g

P/N : 8023/50

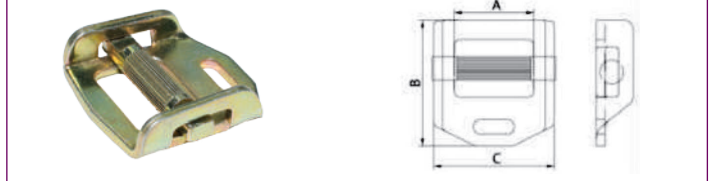

A	B	C	ULTIMATE LOAD	900 daN
51	53	68	WEIGHT	110 g

P/N : 34201/251



A	B	C	ULTIMATE LOAD	50 daN
25	14	2,4	WEIGHT	5 g

P/N : 34201/281

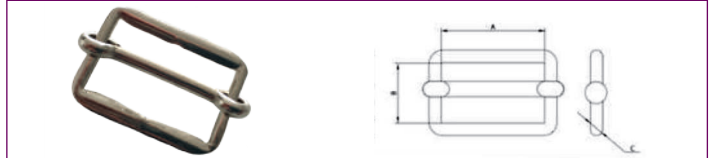

A	B	C	ULTIMATE LOAD	50 daN
28	15	2,7	WEIGHT	8 g

P/N : 34209/271

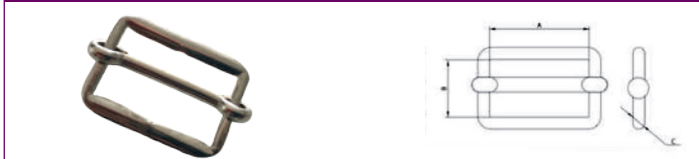

A	B	C	ULTIMATE LOAD	150 daN
27	10	3,9	WEIGHT	14 g

P/N : 34238/154

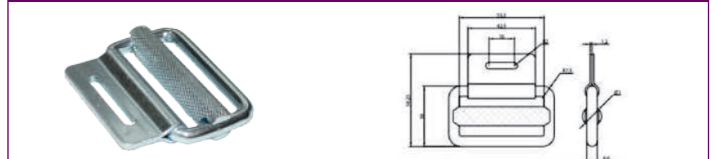

WEBBING	50 mm	ULTIMATE LOAD	800 daN
MATERIAL	Steel - Zinc-plated	WEIGHT	115 g

P/N : 34238/045

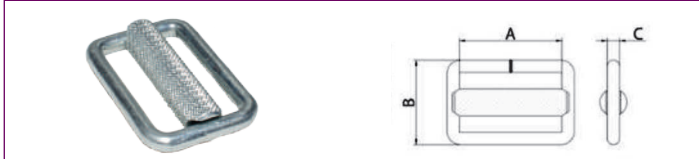

A	B	C	ULTIMATE LOAD	750 daN
45	25	5,9	WEIGHT	71 g

P/N : 34238/054

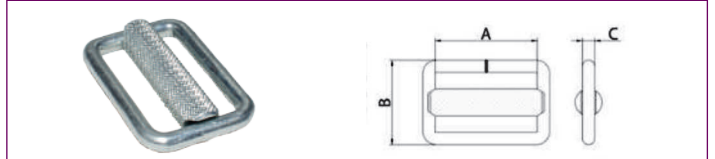

A	B	C	ULTIMATE LOAD	800 daN
54	25	6,4	WEIGHT	85 g

BUCKLE

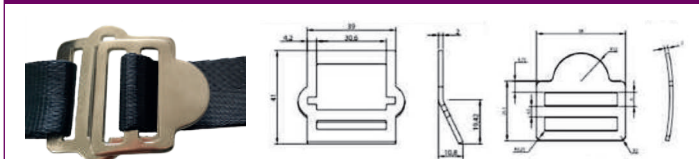

	Female - P/N : 300 B	Male - P/N : 300 C
WEBBING	30 mm	
MATERIAL	Steel - Zinc plated	Steel - Zinc plated
ULTIMATE LOAD	14 g	11 g
WEIGHT	150 daN	

BUCKLE

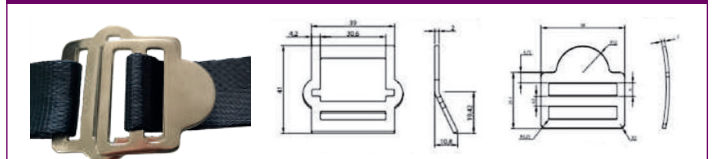

	Female - P/N : 500 B	Male - P/N : 500 C
WEBBING	50 mm	
MATERIAL	Steel - Zinc plated	Steel - Zinc plated
ULTIMATE LOAD	36 g	23 g
WEIGHT	300 daN	

SPARE PARTS

P/N : FS 9016

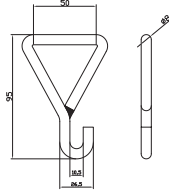

WEBBING	50 mm	ULTIMATE LOAD	1100 daN
MATERIAL	Stainless steel	WEIGHT	95 g

P/N : FS 5013

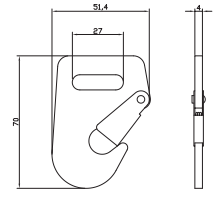

WEBBING	25 mm	ULTIMATE LOAD	900 daN
MATERIAL	Aluminium	WEIGHT	29 g

P/N : FS 5014

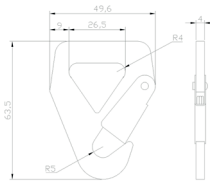

WEBBING	25 mm	ULTIMATE LOAD	450 daN
MATERIAL	Aluminium	WEIGHT	24 g

P/N : 349010-16

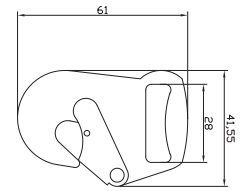

WEBBING	25 mm	ULTIMATE LOAD	1500 daN
MATERIAL	Steel - Zinc plated	WEIGHT	35 g

P/N : 43 044-11



WEBBING	25 mm	ULTIMATE LOAD	2300 daN
MATERIAL	Steel - Zinc-plated	WEIGHT	95 g

P/N : 40 084-14

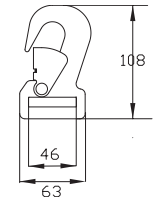

WEBBING	45 mm	ULTIMATE LOAD	3500 daN
MATERIAL	Steel - Zinc plated	WEIGHT	160 g

P/N : 40 758-10



WEBBING	50 mm	ULTIMATE LOAD	5000 daN
MATERIAL	Steel - Zinc-plated	WEIGHT	445 g

P/N : 40 758-11

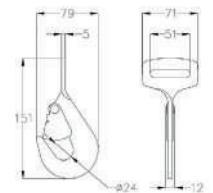

WEBBING	50 mm	ULTIMATE LOAD	5000 daN
MATERIAL	Steel - Zinc plated	WEIGHT	260 g

P/N : 40 191-XX



MATERIAL	Steel forging heat treated and plate		
ULTIMATE LOAD	2890 daN	Several height and thread available	

P/N : FS 5018

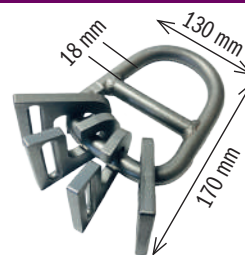

MATERIAL	Inox	ULTIMATE LOAD	10000 daN
WEIGHT	2270 g		

SPARE PARTS

P/N : FS 300

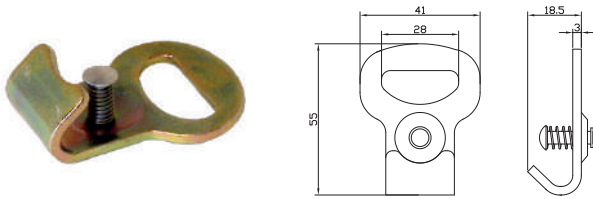

WEBBING	25 mm	ULTIMATE LOAD	1000 daN
MATERIAL	Steel - Zinc-plated	WEIGHT	42 g

P/N : FS 5010

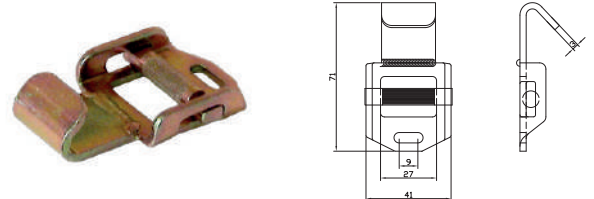

WEBBING	25 mm	ULTIMATE LOAD	800 daN
MATERIAL	Steel - Zinc plated	WEIGHT	74 g

P/N : FS 5012



WEBBING	25 mm	ULTIMATE LOAD	800 daN
MATERIAL	Steel - Zinc plated	WEIGHT	100 g

P/N : 43 977-10

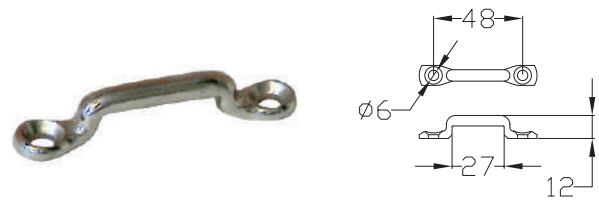

WEBBING	25 mm	ULTIMATE LOAD	900 daN
MATERIAL	Steel - Zinc plated	WEIGHT	16 g

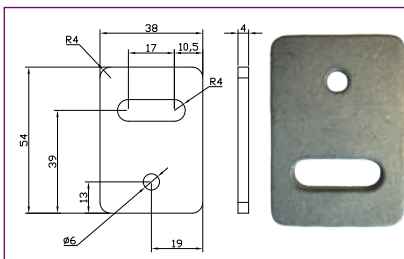

P/N	A83	A85	A85-01	A82	A84-50
WEBBING	25 mm				50 mm
MATERIAL	Steel - Zinc plated	Aluminium		Steel black coated	Steel - Zinc plated
ULTIMATE LOAD	1000 daN	800 daN		900 daN	1200 daN
WEIGHT	57 g	20 g		41 g	103 g

SPECIAL FINISHES AND TREATMENTS

For a simple question of look or for technical reasons, most of our parts may be delivered, on request, with special finishes and treatments.

Gold plated, nickel plated, zinc plated....

ask our technical department for all possible solutions.



Military

Cargo securing solution for NH-90 helicopters	30
Cargo securing solution for SUPER PUMA AS332 helicopters	31
Certified tie down straps ETSO C172	32
Tie down strap for military air transport	33
Tie down strap to secure helicopters on aircrafts carrier	33
Top & side cargo nets for HCU-6 pallet	34
One piece EASA certified cargo net for HCU-6 pallet	35
One piece EASA certified cargo net for 2 coupled HCU-6 pallet	36
Underslung lifting net	37
Easa certified cargo net for PMC/PAG pallet	38



CARGO SECURING SOLUTION FOR NH-90 HELICOPTERS

CARGO NET + TIE DOWN STRAP

P/N	GP GAM161613
NSN	1670-14-578-9654
DIMENSIONS	1970 x 1500 x 1300 mm
TARE WEIGHT	16 kg / 35 lbs
HEIGHT	Adjustable from 0 to 1300 mm
ULTIMATE LOAD	1000 kg
TENSION	6 tie down straps

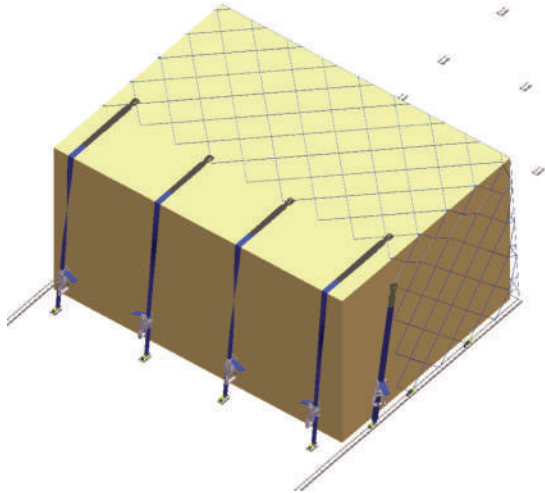

FLOOR FITTING

NSN : 1670-14-578-9663

P/N : FS 2000 AP

Double stud with ring



TIE DOWN STRAP 2250 KG / 5000 IBS

P/N	SMGGLA04005
NSN	1670-14-578-9659
CONFORMITY	ISO 16 049-1
ULTIMATE LOAD	2268 kg / 5000 lbs
ADJUSTABLE LENGTH	mini 0,5 m - maxi 4 m
WIDTH	35 mm
WEBBING	High tenacity polyester, FAR 25.853
COLOUR	Military green
TENSIONING DEVICE	Ratchet buckle 35 mm
END FITTING	Double J hook with retainer (both sides)

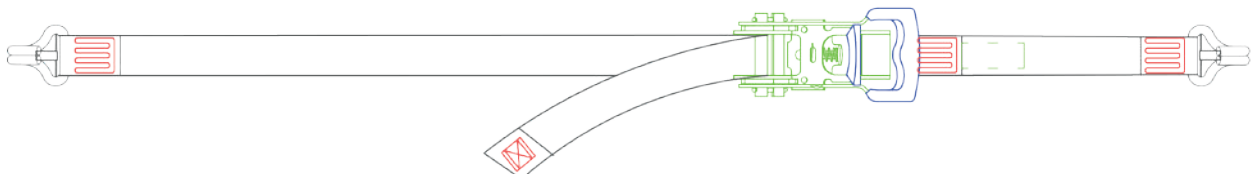

CARGO SECURING SOLUTION FOR SUPER-PUMA AS332 HELICOPTERS

- >> Direct fitting on OEM floor cargo rings
- >> 2 different nets: front & rear cargo compartment
- >> Adjustable to any size and shape of cargo
- >> Total maximum load: 600kg (300 kg per net)
- >> STC certification n° 10037327
- >> Delivered with EASA Form one



FRONT CARGO COMPARTMENT NET	
Direct fitment on OEM floor attachments	
P/N	GP EUFR225ZA-10
NSN	TBD
DIMENSIONS	1750 x 1840 x 1250 mm
TARE WEIGHT	15 kg / 33 lbs
HEIGHT	Adjustable from 0 to 1250 mm
ULTIMATE LOAD	300 kg

REAR CARGO COMPARTMENT NET	
Direct fitment on OEM floor attachments	
P/N	GP EUFR225ZB-10
NSN	TBD
DIMENSIONS	1490 x 1440 x 1250 mm
TARE WEIGHT	15 kg / 33 lbs
HEIGHT	Adjustable from 0 to 1250 mm
ULTIMATE LOAD	300 kg

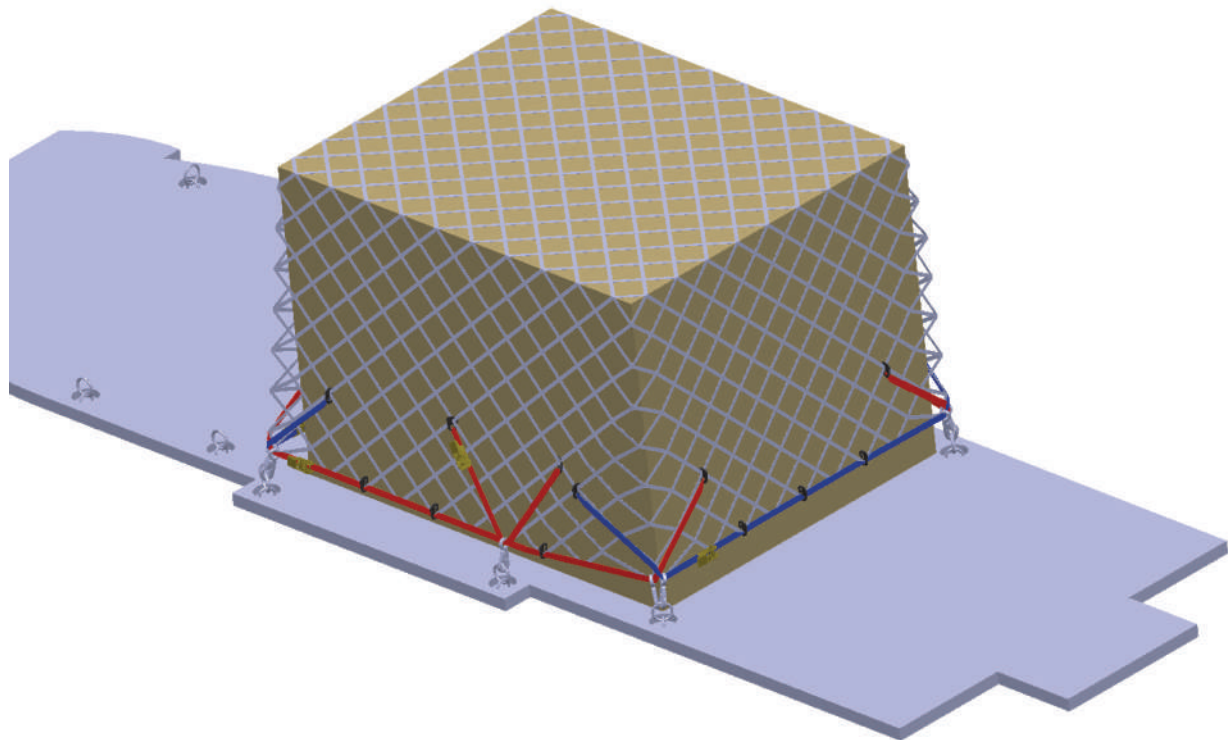

TIE DOWN STRAP ETSO C172



P/N : SLT RANGE

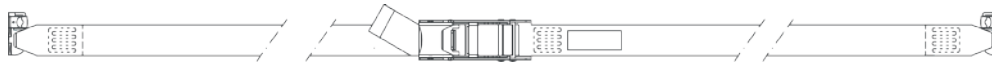

P/N : ST RANGE

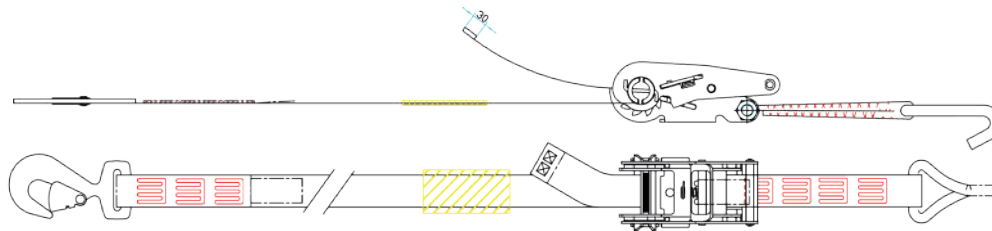

P/N : SHT RANGE

RANGE	SLT	ST	SHT
NSN	TBD	TBD	TBD
DESCRIPTION	High quality tie down strap to secure your cargo on air cargo pallet and in aircraft structure		
CERTIFICATION	EASA Certified ETSO C172 - Delivered with EASA FORM ONE certificate		
ULTIMATE LOAD	907 kg / 2000 lbs	2268 kg / 5000 lbs	4536 kg / 10 000 lbs
TOTAL LENGTH	Standard: 6, 9, 12 meters - Other length on request		
FIXED LENGTH	Standard: 1 meter - Other length on request		
WEBBING	Polyester - 25 mm width	Polyester - 45 mm width	Polyester - 50 mm width
COLOR	Standard: Military green - Other color on request		
END FITTING	V = Flat snap hook S = Single stud M = Flat snap hook + Single stud	P = Double stud C = Flat snap hook Q = Double stud with ring E = Flat snap hook + Double stud G = Flat snap hook + Double stud with ring	Y = Twisted snap hook U = Flat snap hook A = Double J hook with retainer
TENSIONING DEVICE	LG = Ratchet buckle	A3 = Over center buckle LF = Ratchet buckle	LD = Ratchet buckle
LIFE LIMIT	5 years		

TIE DOWN STRAP FOR MILITARY AIR-TRANSPORT



P/N : SIPPL206010-AR



P/N : SICOL406000



P/N	SIPPL206010-AR	SICOL406000
NSN	TBD	3940-14-562-4258
CONFORMITY	ISO 16 049-1	MIL-PRF-27260C
ULTIMATE LOAD	2268 kg / 5000 lbs	
TOTAL LENGTH	Maxi 6 meter	
WIDTH	45 mm	50 mm
WEBBING	High tenacity Polyester FAR 25.853	
COLOR	Military green	White
END FITTING	Flat hook with retainer + double stud fitting (both sides)	Double J hook
TENSIONING DEVICE	Ratchet buckle 45 mm	Ratchet buckle 50 mm
LIFE LIMIT	3 years	

TIE DOWN STRAP TO SECURE HELICOPTERS ON AIRCRAFT CARRIER



P/N : SHZZLC04003

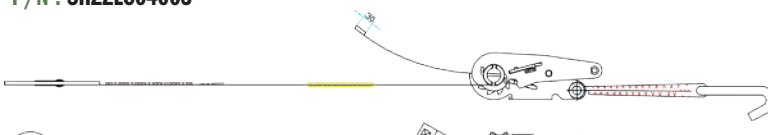

P/N : SHTZILD07003-MIL



P/N	SHZZLC04003	SHTZILD07003-MIL
NSN	TBD	1730-14-5887257
CONFORMITY	ISO 16 049-1	ISO 16 049-1 / ETSO C172
ULTIMATE LOAD	4536 kg / 10 000 lbs	
TOTAL LENGTH	3 to 7 meters	
WIDTH	50 mm	
WEBBING	High tenacity Polyester FAR 25.853	
COLOR	Most colours available	
END FITTING	Reinforced flat hook and/or J hook	
TENSIONING DEVICE	Over center buckle	Ratchet Buckle

TOP & SIDE CARGO NETS FOR 463L / HCU-6 PALLET

TOP PALLET NET HCU-15/C

P/N	GP AR2015-01
NSN	1670-14-536-6275
CONFORMITY	MIL-N-27444D
ULTIMATE LOAD	4536 kg / 10 000 lbs
DIMENSIONS	185" x 166"
MESH DIMENSIONS	250 x 250 mm
WEBBING	100% Polyester - FAR 25.853 + anti abrasion treatment
COLOR	Yellow sand
TARE WEIGHT	17 kg / 38 lbs

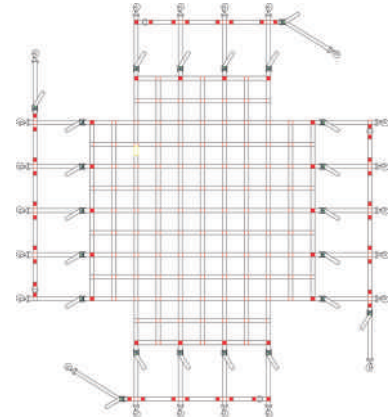

SIDE PALLET NET HCU-7/C

P/N	GP AR2010-01
NSN	1670-14-536-6277
CONFORMITY	MIL-N-2744
ULTIMATE LOAD	4536 kg / 10 000 lbs
DIMENSIONS	195,5" x 65,5"
MESH DIMENSIONS	300 x 300 mm
WEBBING	100% Polyester - FAR 25.853 + anti abrasion treatment
COLOR	Olive drab
TARE WEIGHT	15 kg / 33 lbs

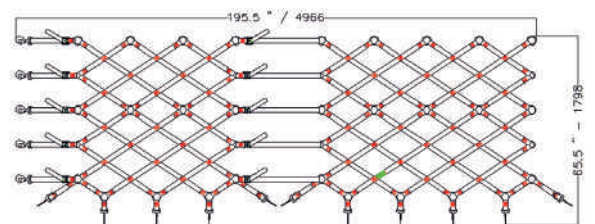

ONE PIECE EASA CERTIFIED CARGO NETS FOR 463L / HCU-6 PALLET

CARGO NET FOR HCU-6 PALLET

P/N	1B6N-N3-096-12
NSN	1670-14-563-2143
DIMENSIONS	88" x 108" x 96"
DESIGN REQUIREMENT	Conform to NAS 3610 and approved ETSO/TSO C90c
DOCUMENTATION	EASA certification n° EASA.210.1234
WEBBING	100% Polyester ; FAR 25.853 + anti abrasion treatment
MESH TYPE	Knotless mesh
TARE WEIGHT	32 kg / 70,5 lbs
ULTIMATE LOAD	4536 kg / 10.000 lbs
LIFESPAN	10 years storage, 5 years in use

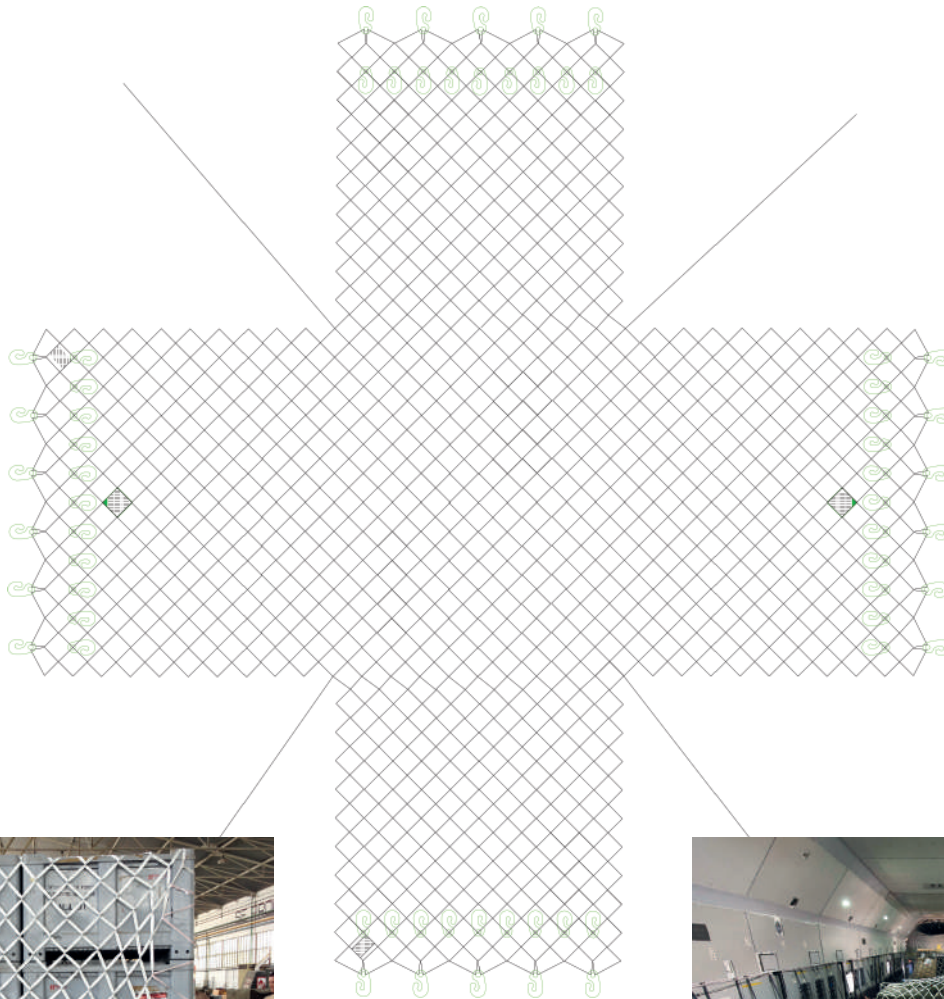

ONE PIECE CARGO NETS FOR 2 COUPLED 463L / HCU-6 PALLET

CARGO NET FOR 463L / HCU-6 DOUBLED

P/N	1B6N-N3-096-10
NSN	1670-14-581-2298
DESIGN REQUIREMENT	Based on NAS 3610
ULTIMATE LOAD	Depends on W&B manual of the aircraft and the pallet + coupler used. Recommended max 13750 lbs
DIMENSIONS	108" x 178" x 96"
TARE WEIGHT	44 kg / 97 lbs
WEBBING	100% Polyester - FAR 25.853
NUMBER OF TIE DOWN HOOKS	32 pcs
NUMBER OF AJUSTING HOOKS	52 pcs
MESH TYPE	Knotless
MESH DIMENSIONS	180 x 180 mm

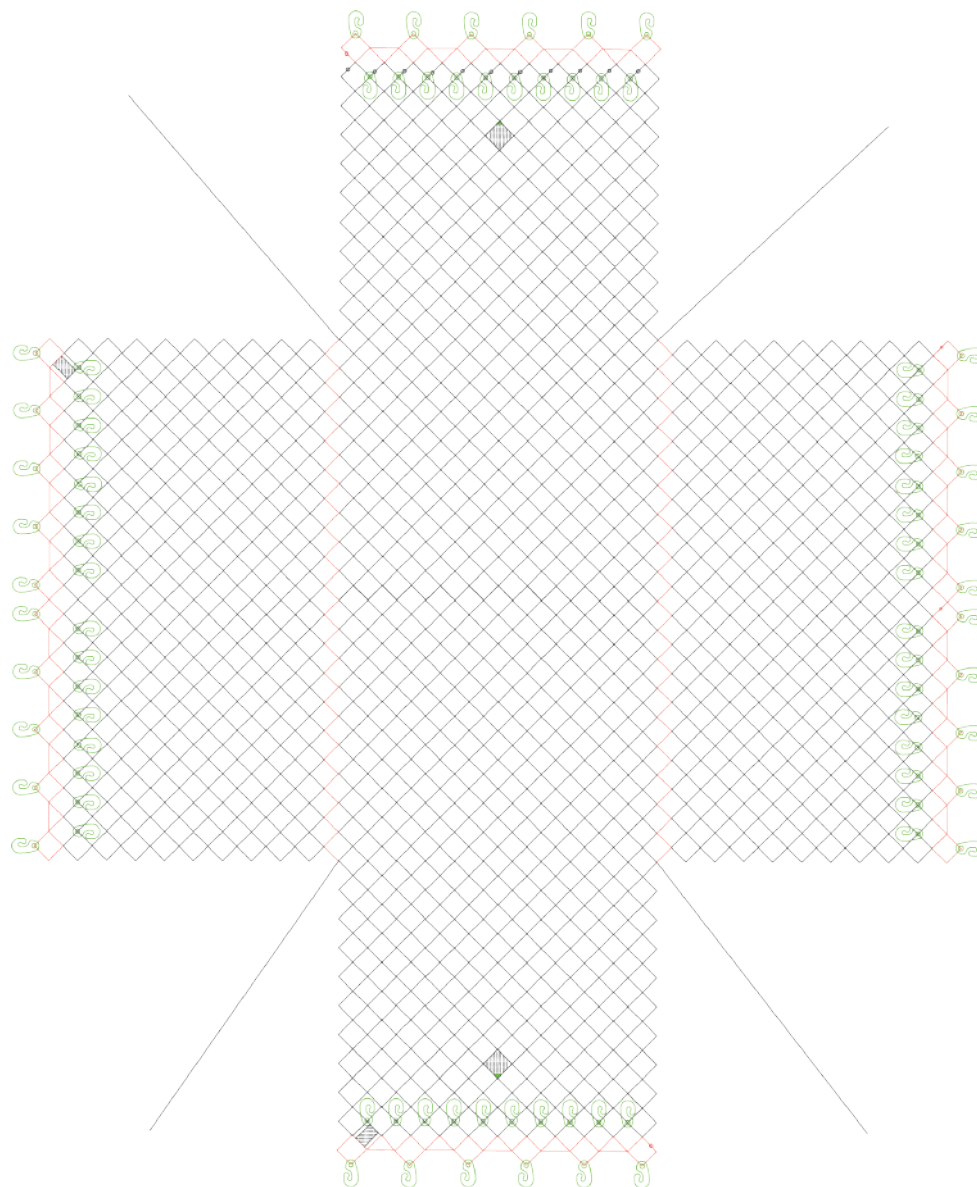

UNDERSLUNG LIFTING NET - 1500 KG / 3300 LBS

UNDERSLUNG LIFTING NET

P/N	GP LN-N15-62X62
NSN	TBD
CONFORMITY	Delivered with certificate of conformance
ULTIMATE LOAD	1497 kg / 3.300 lbs
DIMENSIONS	6,2 x 6,2 m
LOADING PERIMETER	3,5 x 3,5 m
WEBBING	100% Polyester - FAR 25.853
NUMBER OF FITTING RINGS	4 pcs
MESH TYPE	Knotless
MESH DIMENSIONS	125 x 125 mm

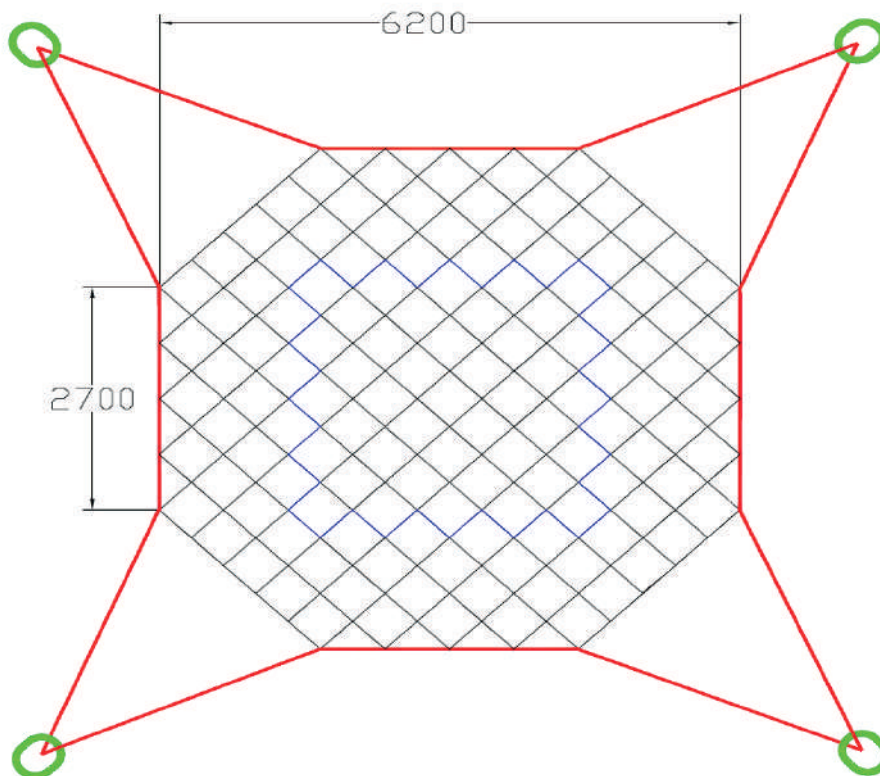

EASA CERTIFIED CARGO NET FOR PMC / PAG PALLET

CARGO NET FOR PMC / PAG PALLET

P/N	2M2N-118-B1-65
NSN	1670-14-559-5545
DESIGN REQUIREMENT	Conform to NAS 3610 and approved ETSO/TSO C90c
ULTIMATE LOAD	6804 kg / 15.000 lbs
DIMENSIONS	88/96" x 125" x 118"
TARE WEIGHT	13 kg / 28 lbs
WEBBING	Polyester - PES
NUMBER OF TIE DOWN STUD	18 pcs
NUMBER OF AJUSTING HOOKS	18 pcs
MESH TYPE	Knotless
MESH DIMENSIONS	250 x 250 mm

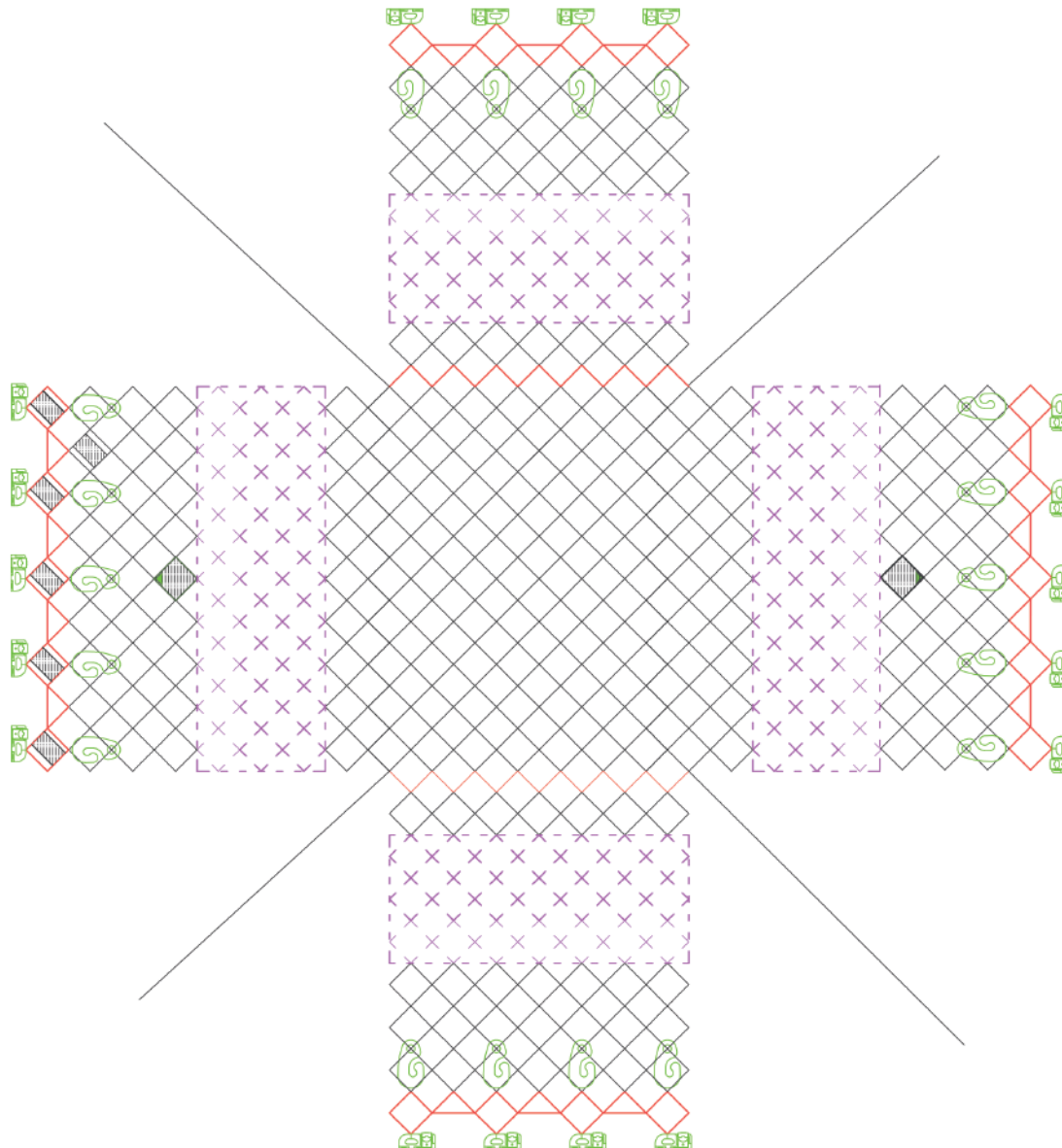

OTHER PRODUCTS FROM THE FORANKRA GROUP

Road lashing	40
One way securing	40
Dock equipment	41
Lifting	41



ROAD LASHING

LASHING LC 2500 daN

P/N: RHEC6E6E0350900084



CORNER PROTECT

ECO-CORNER
P/N: 44973 10 E 240



HEAVY-CORNER
P/N: 05182 11



ANTISLIP MAT CARGOGRIP

P/N: TAG5000X250X4-7210



MULTI-STICK

P/N: EC049119-10



LEX-SEAL

P/N: PLBWL415-LEX



CABLE-LOCK

P/N: PLMETAL210



ONE WAY SECURING

AIRGOBAG

P/N: MATRG90X180-L1VL



STOP-LOAD

P/N: SL24MT1535C2

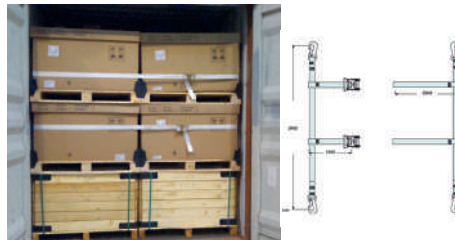

SAFETY-SHEET

P/N: SAFETY-SHEET200X220



CORNER PROTECT ONE USE

P/N: C0100X100X400-5



SECU-LOCK

P/N: PLFDS3



CONTENEURBLOCK

P/N: PL1418-17712



DATA LOGGER

P/N: TMS110



THERMAL LINER ISOLEX

P/N: ISOLEX20-10



DESICANT ULTRA-DRY

P/N: ULTRADRY1000-20



DOCK EQUIPMENT

TRAILOR JACK

P/N: 48780 200



WHEEL CHOCK

P/N: 93.951.416.KC



ALUDOCK

P/N: PLA1400X550-AL

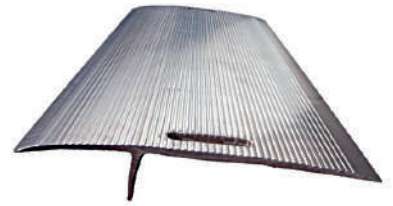

DOCK LEVELER SPEED-DOCK

P/N: SPD249X105X76

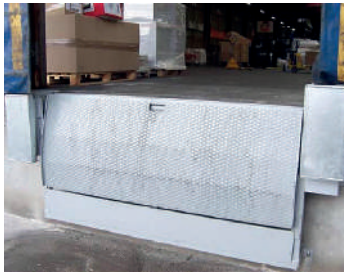

DOCK LEVELER FLASH-DOCK

P/N: 48916 10-1065X2000



BUMPER STEEL-BOX

P/N: 49107 10 Z



SLAVE PALLETS /DOLLIES

CONSULT US



SECTIONNAL DOOR

CONSULT US



TEXTILE BARRER

CONSULT US



LIFTING

TEXTILE SLING

CONSULT US



CHAIN SLING

CONSULT US

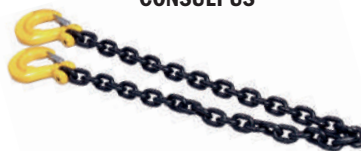

ACCESSORIES

CONSULT US



INDEX

DESIGNATION	P/N	PAGE
PMC/PAG CARGO NET - HEIGHT 64''	2M2N-B2-064-30	9
PMC/PAG CARGO NET - HEIGHT 96''	2M2N-B2-096-30	9
PMC/PAG CARGO NET - HEIGHT 118''	2M2N-B2-118-30	9
PLA CARGO NET - HEIGHT 64''	2L3N-064-B1-21	9
PLA CARGO NET - HEIGHT 80''	2L3N-64-B1-22	9
PKC CARGO NET - HEIGHT 64''	2K3N-064-B1-01	9
PKC CARGO NET - HEIGHT 80''	2K3N-064-B1-02	9
PGA-PGF CARGO NET - HEIGHT 96''	2G1N-096-R2-12	9
PGA-PGF CARGO NET - HEIGHT 118''	2G1N-096-R2-10	9
TIE-DOWN STRAP 2000 lbs	SLTXXXXXXXX	11
TIE-DOWN STRAP 5000 lbs	STXXXXXXXX	11
TIE-DOWN STRAP 10 000 lbs	SHTXXXXXXXX	11
THERMAL COVER	GP T CXXXXXXXX	12
FIRE CONTAINMENT COVER	FCB-096-50 NSN: 4210-14-563-7900	12
VEHICULE STRAP	SR2PL5-400	13
CARGO STOPPER	STP 120/STP140	13
FITTING - SINGLE STUD WITH RING	FS 700	13
FITTING - DOUBLE STUD WITH RING	FS 2000 AP	13
SECURITY SEAL - 1,5 MM	PLSCC15-250	13
SECURITY SEAL - 3,5 MM	PLSCC35-250	13
SECURITY SEAL - 5 MM	PLSCC50-250	13
MULTI STICK	GP MSSS1030	13
ATR 9G BARRIER NET	0110-09-0A-6100EPA GPI: GP AT3000-01	17
ATR 9G BARRIER NET	0110-09-0A-6101EPA GPI: GP AT3010-01	17
ATR 9G BARRIER NET	9000-01-A-6017-F01EPA GPI: GP AT3017-01	17
ATR 9G BARRIER NET	0110-09-0A-6102EPA GPI: GP AT3012	17
ATR 9G BARRIER NET	9000-01-A-6018-F01EPA GPI: GP AT3018	17
SAAB 9G BARRIER NET	25-63-10300 GPI: GP TA151-6	17
SAAB 9G BARRIER NET	25-63-10301-2 GPI: GP TA151-3	17
SAAB 9G BARRIER NET	25-63-10299-1 GPI: GP TA153-1	17
SLOTTED WEBBING 13 MM	723/13B	22
SLOTTED WEBBING 15 MM	723/13R	22
SLOTTED WEBBING 18 MM	723/18	22
FLAT WEBBING 20 MM - ASNA 3573-5919	1163/20	22
FLAT WEBBING 25 MM - ASNA 3573-5926	84 044/25-NO	22
FLAT WEBBING 25 MM - ASNA 3573-5925	98 323/25	22
FLAT WEBBING 25 MM - ASNA 35735925	20 319/25	22

DESIGNATION	P/N	PAGE
FLAT WEBBING 45 MM	0303007/45	22
FLAT WEBBING 48 MM - 2500 daN - BLACK	84 015/50-NO	22
FLAT WEBBING 48 MM - 2500 daN	85 017/50	22
FLAT WEBBING 50 MM - 5000 daN	94 187/50	22
FLAT WEBBING 50 MM - 7500 daN	93 168/50	22
FLAT WEBBING 60 MM - 9000 daN	6592/60	22
FLAT WEBBING 75 MM - 15000 daN	6551/75	22
TUBULAR WEBBING - 15 MM - 1800 daN	724/15	22
VELCRO MALE - ASNA 35461875	AP 800/24-M	22
VELCRO FEMALE - ASNA 35461875	AP 800/24-F	22
GAINE	SPB 103	22
STRAP PROTECTION SHEATH	46 137-75	22
TARPOLIN - GREY	32 261 A	23
TARPOLIN - BLUE	32 263 B	23
RASCHEL NETTING	FX 999	23
ANCHOR PLATE	40 000-11	23
DOUBLE ANCHOR PLATE	520 197-40	23
SEAT TRACK	40 456-10	23
SEAT TRACK	40 467-11	23
SEAT TRACK	40 456-51	23
SEAT TRACK	40 986-2000	23
OVER CENTER BUCKLE - 45 MM - 2250 daN	47 800-10	24
ANTI SLIPPAGE OVER CENTER BUCKLE - 45 MM - 2250 daN	48 857-20	24
OVER CENTER BUCKLE - 50 MM - 800 daN	46 067-10	24
OVER CENTER BUCKLE - 25 MM - 2000 daN	42 816-12	24
CAM BUCKLE - 25 MM - 250 daN	41 030-17	24
CAM BUCKLE - 45 MM - 700 daN	42 195-10	24
CAM BUCKLE - 35 MM - 700 daN	48 343-10	24
CAM BUCKLE - 45 MM - 700 daN	40 880-19	24
RATCHET BUCKLE - 25 MM - 750 daN	44 232-10	25
RATCHET BUCKLE - 25 MM - 750 daN - STAINLESS STEEL	44 232-10 SS	25
RATCHET BUCKLE - 25 MM - 2000 daN	43 320-12	25
RATCHET BUCKLE - 50 MM - 5000 daN	46 405-10	25
RATCHET BUCKLE - 50 MM - 5000 daN	44 627-10	25
BUCKLE - 50 MM - 1300 daN	34 900/001	25
RATCHET BUCKLE - 50 MM - 5000 daN	47 105-17	25
SNAP LATCH	45 387-10	25
SLIDE BUCKLE - 25 MM - 800 daN	8023/25	26

INDEX

DESIGNATION	P/N	PAGE
SLIDE BUCKLE - 50 MM - 900 daN	8023/50	26
SLIDE BUCKLE - 25 MM - 50 daN	34201/251	26
SLIDE BUCKLE - 50 MM - 800 daN	34238/154	26
SLIDE BUCKLE - 30 MM - 150 daN	300 B/C	26
SLIDE BUCKLE - 50 MM - 300 daN	500 B/C	26
SLIDE BUCKLE - 50 daN	34 201/281	26
SLIDE BUCKLE - 150 daN	34 209/271	26
SLIDE BUCKLE - 750 daN	34 238/045	26
SLIDE BUCKLE - 800 daN	34 209/054	26
HOOK - 1100 daN	FS9016	27
HOOK - 900 daN	FS5013	27
HOOK - 450 daN	FS5014	27
HOOK - 5000 daN	349010-16	27
HOOK - 2300 daN	43044-11	27
HOOK - 3500 daN	40084-14	27
HOOK - 5000 daN	40 758-10	27
HOOK - 5000 daN	40 758-11	27
SPECIAL STUD WITH THREAD	40 191-XX	27
LIFTING NET HOOK ASSEMBLY	FS 5018	27
FOOTMAN HOOK - 1000 daN	FS300	28
FOOTMAN HOOK- 800 daN	FS5010	28
FOOTMAN HOOK - 800 daN	FS 5012	28
FOOTMAN LOOP - 900 daN	43 977-10	28
HOOK - 1000 daN	A83	28
HOOK - 800 daN	A85	28
HOOK - 800 daN	A85-01	28
HOOK - 900 daN	A82	28
HOOK - 1200 daN	A84-50	28
CARGO NET FOR NH-90 CARGO COMPARTMENT	GP GAM161613 NSN: 1670-14-578-9654	30
FLOOR FITTING FOR NH-90 CARGO COMPARTMENT	FS 2000 AP NSN: 1670-14-578-966	30
STRAP FOR NH-90 CARGO COMPARTMENT	SMGGLA04005 NSN: 1670-14-578-9659	30
CARGO NET FOR SUPER PUMA AS332 FRONT CARGO COMPARTMENT	GP EUFR225ZA-10	31
CARGO NET FOR SUPER PUMA AS332 REAR CARGO COMPARTMENT	GP EUFR225ZB-10	31
STRAP FOR MILITARY PURPOSES - 2250 KG / 5000 LBS	SIPPL206010-AR NSN: 3940-14-562-4258	33
STRAP FOR MILITARY PURPOSES - 2250 KG / 5000 LBS	SICOL406000	33
STRAP FOR MILITARY PURPOSES - 4450 KG / 10000 LBS	SHZZLC04003	33
STRAP FOR MILITARY PURPOSES - 4450 KG / 10000 LBS	SHTZILD07003-MIL	33

DESIGNATION	P/N	PAGE
TOP PALLET NET HCU-15	GR AR2015-01 NSN: 1670-14-536-6275	34
SIDE PALLET NET HCU-7	GP AR2010-01 NSN: 1670-14-536-6277	34
ONE PIECE CARGO NET FOR HCU-6 PALLET	1B6N-N3-096-12 NSN: 1670-14-563-2143	35
ONE PIECE CARGO NET FOR 2 COUPLED HCU-6 PALLET	1B6N-N3-096-10 NSN: 1670-14-581-2298	36
UNDERSLUNG LIFTING NET	GP LN-N15-62X62	37
EASA CERTIFIED CARGO NET FOR PMC/PAG MILITARY PALLET	2M2N-118-B1-65 NSN: 1670-14-559-5545	38
LASHING LC 2500 daN	RHEC6E6E0350900084	40
ECO-CORNER	44973 10 E 240	40
HEAVY-CORNER	05182 11	40
ANTISLIP MAT CARGOGRIP	TAG5000X250X4-7210	40
MULTI-STICK	ECO49119-10	40
LEX-SEAL	PLBWL415-LEX	40
CABLE-LOCK	PLMETAL210	40
AIRGOBAG	MATR90X180-L1VL	40
STOP-LOAD	SL24MT1535C2	40
SAFETY-SHEET	SAFETY-SHEET200X220	40
CORNER PROTECT ONE USE	CO100X100X400-5	40
SECU-LOCK	PLFDS3	40
DESICANT ULTRA-DRY	ULTRADRY1000-20	40
SEAL CONTENEURBLOCK	PL1418-17712	40
DATA LOGGER	TMS110	40
THERMAL LINER ISOLEX	ISOLEX20-10	40
TRAILOR JACK	48780 200	41
WHEEL CHOCK	93.951.416.KC	41
ALUDOCK	PLA1400X550-AL	41
DOC LEVELER SPEED-DOCK	SPD249X105X76	41
DOC LEVELER FLASH-DOCK	48916 10-1065X2000	41
BUMPER STEEL-BOX	49107 10Z	41
SLAVE PALLETS / DOLLIES	CONSULT US	41
SECTIONNAL DOOR	CONSULT US	41
TEXTILE BARRER	CONSULT US	41
TEXTILE SLING	CONSULT US	41
CHAIN SLING	CONSULT US	41
ACCESSORIES	CONSULT US	41

Restraint solutions
for the aerospace industry



ZA la Bohalle
49800 La Bohalle - FRANCE
Office: +33 (0)2 41 54 90 60
Fax: +33 (0)2 41 80 49 82
gpi@gpi-int.fr

www.gpi-int.fr